

Vulcraft NuBIM® Add-in for Revit®

User Manual 2017v2 - 2022



NUCOR®
VULCRAFT/VERCO

Powerful Partnerships
Powerful Results

Nucor's Vulcraft/Verco would like to introduce you to the NuBIM® Add-In for Revit. The NuBIM® Add-In was designed to improve the joist and deck specification process, streamlining the work-flow of specifying your joist and deck families in Revit. The new tool will allow you to more completely specify your joist and deck, improve your detail drawings and load schedules, while saving you time by keeping your model in sync with your drawings.

[Here are just a few of the many enhancements we have made based on a lot of great feedback from users like yourself](#)

- Batch Printer - Our new Batch Printing tool can create individual or combined pdfs from your drawing sheets. It also will automatically select the correct paper size for the sheet, and allow you to create combined pdfs with multiple sheet sizes.
- Automatic Load Application - Stock Revit model loads can now be applied to our joist families. Once the loads are placed in the model, the Consider Loads tool will distribute and apply the loads to the joists. The load diagrams for each joist can also be created at the same time.

The Vulcraft NuBIM® Add-In allows you to insert a variety of Vulcraft joists and deck into your Revit model. All types of parallel chord joists and girders are available as well as a large number of Special Profiles. The User Input(UI) allows you to specify joist types and desired end conditions. The NuBIM® Add-In also recognizes joist supports and will automatically offset and slope (if needed) the joists as you place them, removing the need to move families to allow for the bearing seat depth. Joist loading schedules can also be completed that allow a variety of load types to be applied to the joists.

Vulcraft/Verco Deck profiles can also be specified with the Add-In. You have the ability to select profile, gauge, and finish, then apply the profile to an existing floor/roof type or create a new floor/roof with the desired deck profile. The deck family profiles can also be viewed in your section cuts, which simplifies the generation of roof and floor details.

Once the model is complete, the Job Export tool can be used to export all the Vulcraft/Verco joist and deck information along with basic project information to your local sales office. This will allow for faster and more accurate pricing for budgeting and bid purposes as well as increased quality of service and project coordination. (*Quote capability still under development. Please contact you're local Vulcraft office for more information)

Installation:

After the Add-In is downloaded from vulcraft.com/DesignTools/RevitDownloads, please close all versions of Revit you may have open before running installer. After installer finishes, the NuBIM tool tab will appear in Revit.

For additional assistance with installation, see installation guide.

Note: Be sure to download the correct version of the Add-In for the version of Revit you are using.

Please contact bim@vulcraft.com with any questions.

TABLE OF CONTENTS

Place/Update Joist	4
•Select Series/Profile	4
•Bearing Details	5
•Joist System	5
Economic Joist Converter	7
Joist Loading Information	8
•Point Loads	8
•Drift Loads	8
Dynamic Load Diagrams	9
Consider Loads	10
Joist Marking and Tagging	11
Tag Joist Ends	12
Match Joist Properties	13
Deck Specification	14
•Profiles	14
•Gauge/Finish	14
•Create Floor/Roof	15
Batch Print	16
Job Setup/Export	17
Additional Features	18

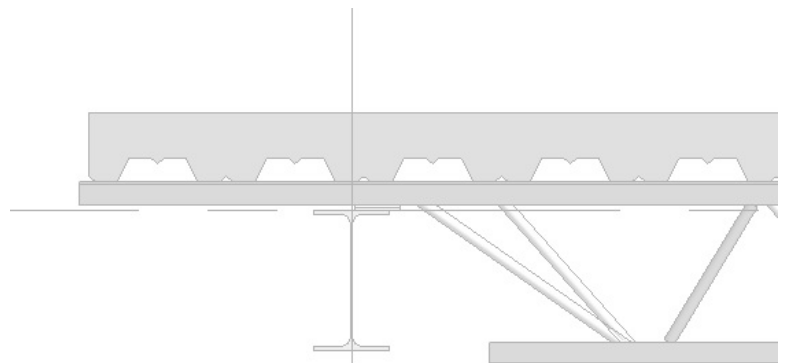
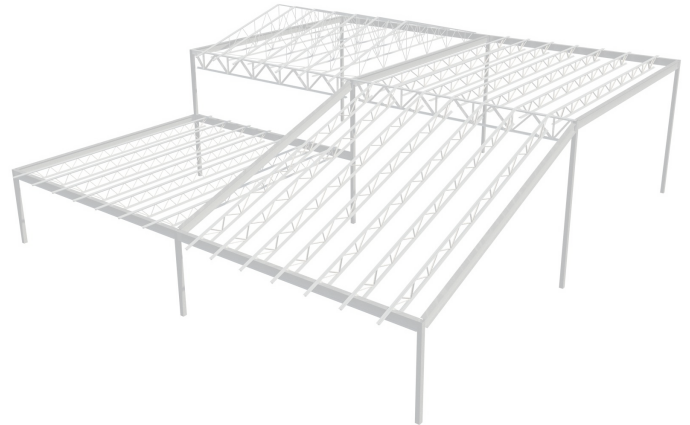

PLACE OR UPDATE JOIST/SYSTEM



This will open the NuBIM® Tool Primary UI. Within this tool you will be able to select and specify all types (2.5K, K, LH, DLH, Ecospan®, CJ(Composite Joist), Joist Girder) of Vulcraft’s standard joists as well as a variety of special profile joists (Arched Chord, Bow String, Double Pitch, Multi Pitch, Scissor, Single Pitch).

- Now the joist designation may be typed in, instead of being selected. Just begin typing the designed designation and a dropdown will appear with options to pick from or you may type in the entire designation.
- After typing in the designation you must hit tab or enter select that designation, and update the other dropdowns.
- You still have the ability to select your joist via the drop down menus.

Note: Designation will auto-populate as joist is specified. Designation will be your joist naming tag.

If a Total Load/Live Load (TL/LL) joist is required, select one of the depth only profiles. When you select the Loads checkbox, the TL and LL fields will be made available for you to input the required loading. Please input the loading in pounds per lineal Foot (PLF)

Ecospan® and Composite Joists work in a similar fashion to TL/LL Joists. First a depth must be selected, then the required loading is input. Please input the loading in Pounds Per Lineal Foot (PLF)

For Joist Girders, after the depth and type (G, BG, or VG) is selected from the profile drop-down, the number of equal spaces (panels) and loading can be input.



The **Special Joist** checkbox allows you to add an SP to the end of a TL/LL joist designation if needed.

20K

LF) ? Special Joist 2 ?

20K 200/100 SP2 - J3

14K400/250SP

Design for a minimum of a 14K400/250 and also design the second load case based on the SP requirements. (Load diagram required for SP)

The **Joist Ends** section of the tool allows you to input all the relevant dimensions related to the specification of the end and bearing conditions of a joist or joist girder.

- End of TC (TCX): Length of Joist Top Chord from center of support to end of joist
- Seat Depth: Depth of joist seat at center of support
- End of BC: Distance from last bottom chord panel point to end of bottom chord. If the BCX checkbox is not checked, a default BC length will be used
- Square End: Allows for bottom chord bearing condition on either end of joist, if both ends are to be square end, use Bottom Chord Bearing Option (see Additional Parameters).

Joist Ends

	END 1	END 2
End of TC (TCX):	0"	0"
Seat Depth:	2.5"	2.5"
BC Extension (BCX):	<input type="checkbox"/> 0"	<input type="checkbox"/> 0"
Square End:	<input type="checkbox"/>	<input type="checkbox"/>

Copy to End 2 Swap Ends Copy to End 1

The **Additional Parameters** section allows you to tag the joists as they are placed. This section also allows you to convert the joist to Bottom Chord Bearing.

Note: Bottom Chord Bearing will move the entire joist up to bear on the bottom chord.

Once you have set all the joist parameters you can select **Place Joist** to insert a single joist into the model or you can also select **Joist System** which allows you to place a joist system similar to Revit's Beam System Tool.

Note: Before placing joists, be sure to have 3D Snapping selected.

Additional Parameters

Tag on placement Bottom Chord Bearing

Joist System

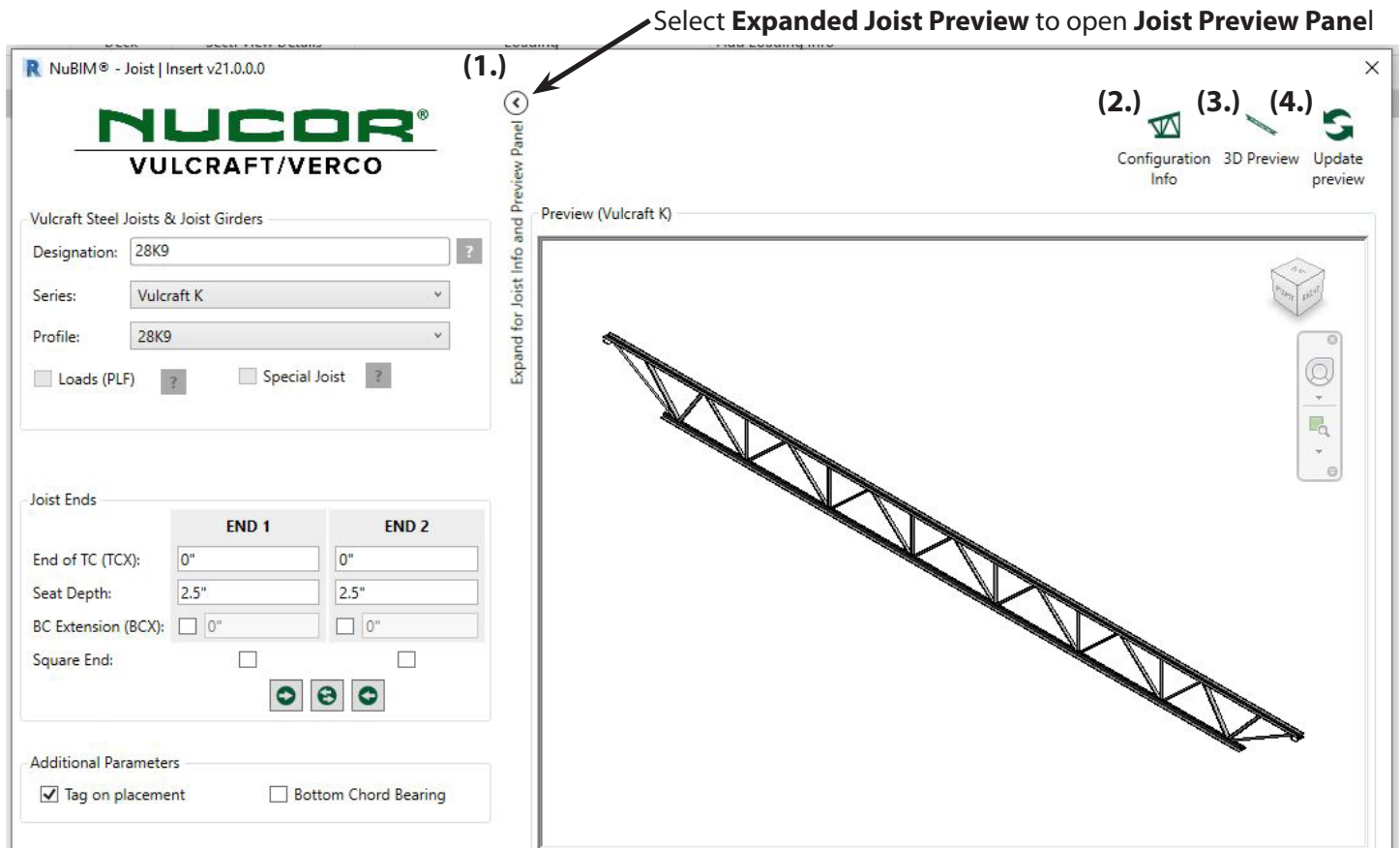

(1.)The Joist Preview Panel provides a flyout for 3D preview of the joist that is being specified with the tool before the joist is placed. The preview model can be rotated and zoomed in and out. (4.)After data is input, select Update Preview to update the preview model.

Note: Since this is a separate model view, length is based on a default length, so the depth to length ratio may look disproportionate at times.

(2.)Configuration Info brings up a diagram that graphically shows the locations of the dimensions that can be input within the tool to specify a joist based on the series chosen.

(3.) To return to the 3D preview select the 3D Preview button.

Edit/Update Joist(s)

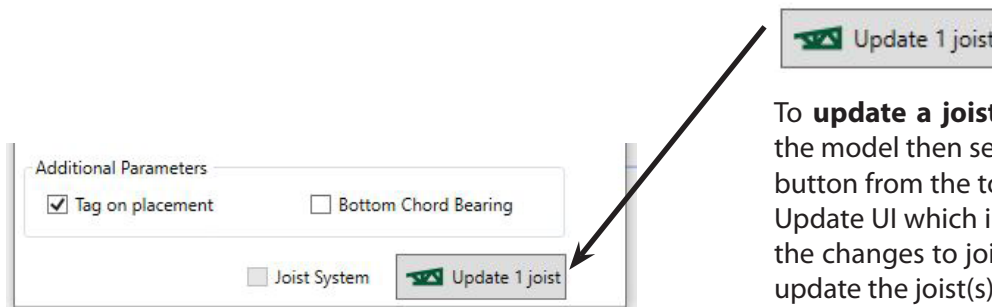

To **update a joist or joists:** First, select the joist(s) in the model then select the Place or Update Joist/System button from the tool ribbon. This will bring up the Joist Update UI which is the same as the Insert Joist UI. After the changes to joist(s) are made, select Update Joist to update the joist(s).

Note: A counter will tell you how many joists you are updating.



The **Economic Joist Converter** is a dockable pane that can be left open at all times. The Economic Converter allows you to select one or more joists in the model, input a max depth and loading, and it will select the most economical joist for the given span, based on the Vulcraft joist catalog's Economical Joist Guide.

Note: The Economic Joist Converter does not take any loading input through the Joist Loading Information tables into consideration when selecting joists.

To use the Economic Converter, first select the joists you wish to convert and then select **Refresh Joist List**, this will load the selected joists into the User Interface.

Refresh Joist List

Note: If Show Non-Vulcraft is checked, the Economic Converter will allow you to convert beams and any standard Revit joists to Vulcraft joists.

After the joists are loaded a drop down selection will be available based on the Max Depth & Loading values entered. If the length shows as **Red**, a more economic joist may be available.

Note: Determination of economies is based on an estimated joist weight per foot. Engineer's design and judgment for true economies are still required.

The **Zoom** Button will highlight and zoom to the selected joist in the model.

After you have selected what joists you would like to update, select the **Update Checked** button to update the joists in the model.

Update Checked

Note: All the joists you have loaded in the Economic Joist Converter are checked by default, if you do not want a certain joist updated, uncheck the check box.

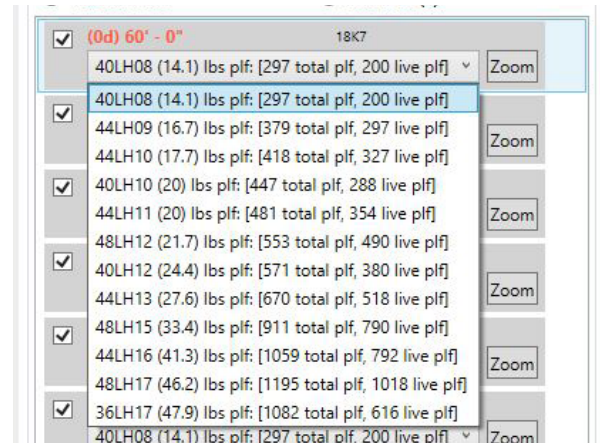
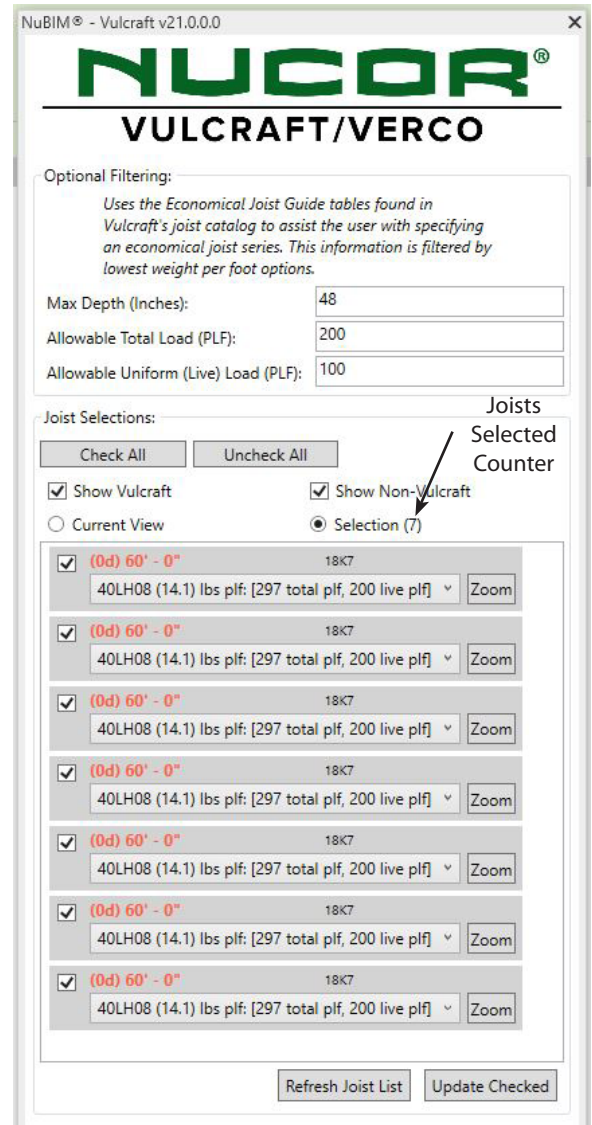



Joist Loading Information allows you to apply various types of loads to individual joists and creates loading tables that can be placed on drawings. The loading that is applied to the joists is also considered when joists are marked using **Joist Marking and Tagging** (See Page 10).

Select the joists you would like to apply loading to, then select the **Joist Loading Information** button from the tool button. This will bring a dialog that will let you select what type of loads you want to apply (Point or Drift Loads).

After you select the type of loads you would like to apply, that particular loading table will be brought up. All of the loading tables will be loaded into the project, and can be accessed through the project browser at any time.

Once the table for the type of loads you would like to apply is open, you simply go through the table and input the loads as you need them, the units for the loads will come in automatically.

Note: The tables can be adjusted to show joists by their marks with a count of that joist mark. This will eliminate unnecessary information in the schedules. Revit schedules can be placed on your contract drawings which will allow you to keep your specification information in one place, Revit.

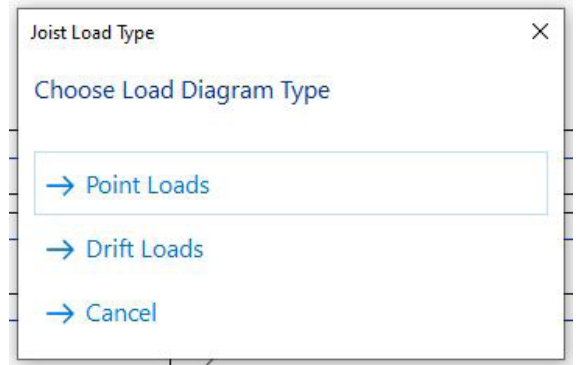

Note: The Selection Filter Tables can be accessed by selecting the joists you wish to apply loading too, and then selecting the Joist Loading Info Tool. These tables will show all the joists selected, but they will be grouped by mark.

New for 2018: Hide/Unhide Columns allows you to hide any empty columns in the load tables, creating simpler cleaner tables when needed.

NOTES:

- "Add Load" is a concentrated load at any panel point (Kips)
- "TCX Load" is assumed at the end of the TCX.
- Dimension "D/1" = Indicates the distance from End 1 bearing location (ft-in)
- Dimension "D/2,3,4,5" = Indicates the distance from previous load (ft-in)
- All loads are assumed to be imposed on the Top Chord ONLY.
- All Loads are considered to be Service Level Factored ASD.

A	B	C	D	E	F	G	H	I	J	K	L	M	N	O	P
Designation	Mark	Add Load	TCX-Top Chord Ext		Point Load 1		Point Load 2		Point Load 3		Point Load 4		Point Load 5		Selection Filter
			End 1	End 2	Load	Dist	Load	Dist	Load	Dist	Load	Dist	Load	Dist	
18K4	J1	0.25 kip	5.00 kip	5.00 kip	5.00 kip	6' - 0"	5.00 kip	5' - 0"	5.00 kip	5' - 0"	5.00 kip	5' - 0"	5.00 kip	5' - 0"	<input checked="" type="checkbox"/>
18K4	J1	0.25 kip			5.00 kip	6' - 0"									<input checked="" type="checkbox"/>
J1: 2															
18K4	J2														<input checked="" type="checkbox"/>
18K4	J2														<input checked="" type="checkbox"/>
18K4	J2														<input checked="" type="checkbox"/>
J2: 3															

NOTES:

- Dimension "A" = Indicates the starting point of the drift load from End 1 (ft-in)
- Dimension "B" = Indicates the beginning magnitude of the drift load (psf)
- Dimension "C" = Indicates the ending magnitude of the drift load (psf)
- Dimension "D" = Indicates the length of the drift load (ft-in)
- Drift loads are assumed to be imposed on the Top Chord ONLY.
- All Loads are considered to be Service Level Factored ASD.

A	B	C	D	E	F	G	H	I	J	K	L	M	N	O	P	Q	R	S
Mark	Count	Designation	Uplift	Live Load Moment		Lateral Load Moment		Axial (Chord) Forces		Axial Load Type:	Drift Load 1				Drift Load 2			
				End1	End2	End1	End2	Top	Bottom	None, Seismic, or Wind	A (Start Location from End 1)	B Load	C Load	D (Length of Drift)	A (Start Location from End 1)	B Load	C Load	D (Length of Drift)
J1	2	18K4									0' - 0"	45.00 lb/ft	0.00 lb/ft	15' - 0"				
J2	3	18K4									0' - 0"	35.00 lb/ft	0.00 lb/ft	10' - 0"				
J3	1	18K3																
J4	6	18LH02																

Dynamic Load Diagram allows you to create load diagrams for joists that you have applied loading information to through the **Joist Loading Information** tool.

To create a **Load Diagram** after you have applied loading information, first cut a section view showing the joist you wish to create the diagram of.

Once in the **Section View** you can begin creating the **Load Diagram**. First select the **Dynamic Load Diagram** tool from the tool ribbon, this will bring up the Load Diagram UI.

If other joists are visible in the view, and have loading that differs from the joist you are creating the load diagram for, select the joist you are referencing and check the **Selected Joists Only** check box.

You have a number of options to choose from when creating your load diagram:

- **Load Tags:** This will place tags on the diagram with the values of the loads shown
- **Load Dimensions:** Selecting this will add dimensions to the diagram showing the locations of the various loads
- **Joist Designation:** Selecting this will add the joist designation to the diagram
- **Joist Mark:** Selecting this will add the joist mark to the diagram
- **Automatically Scale Whole Joist Loads:** If the joist is TL/LL joist this will automatically adjust the size of the uniform load graphic to fit the diagram
- **Manually Scale Whole Joist Loads:** If the joist is TL/LL joist, this will allow you to manually adjust the scale of the uniform load graphic.
- **Line Load Fixed Height:** If the joist is a TL/LL joist this will make the uniform load graphic a fixed height

After you have selected the desired options for your load diagram, select **Create/Update Diagram** to create the diagram. *To update a diagram follow the same process as creating the original diagram.*

Once the diagram is created the dimensions and tags can be moved around just like any other dimensions and tags in Revit.

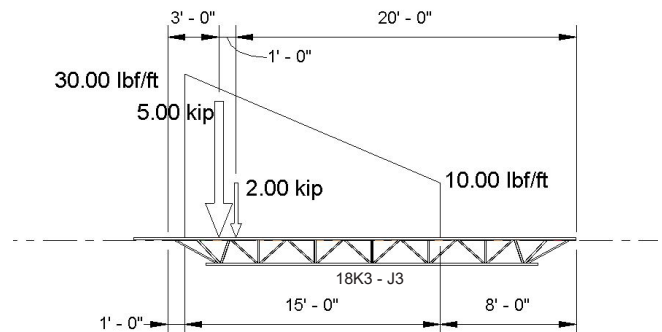
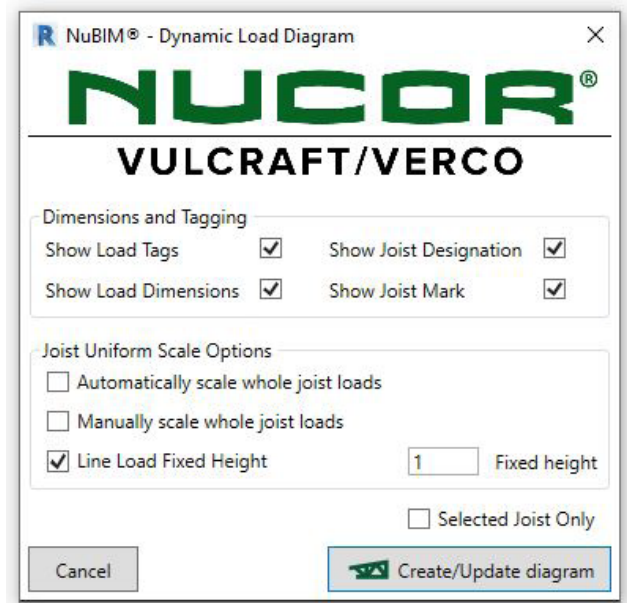

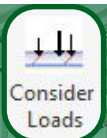

Consider Loads allows you to apply loading placed via Revit's built in loading tools to Vulcraft joists. Currently only point loads and line loads can be applied to Vulcraft joists through the **Consider Loads** tool. If uniform or drift loading needs to be applied to your joists please use the [Joist Loading Information](#) tool.

Before running the **Consider Loads** tool you must place your loads using Revit's built in load tools. You can access these from the shortcut on the NuBIM toolbar or in their typical location on the Analyze tab.

There are several analysis assumptions made by the **Consider Loads** tool.

- All floors/decking is assumed to be single spanning between joists in the direction of the floor span defined in the floor boundary.
- Any loads which extend beyond their supporting joists (cantilevers) will be ignored.
- Any loads which extend beyond the floor boundary will be ignored.
- All sloped floors will be ignored
- Pattern loading is not considered

Note: For Consider Loads to function properly, you must have the span direction of your floor set correctly.

After placing the desired loads in the model, select **Consider Loads** to bring up the Consider Loads UI. From here you can select which types of loads you wish to consider. There is also the option to create load diagrams for each joist. This using the same functionality of the **Dynamic Load Diagram** tool.

Once you have selected which loads to consider and if you wish to create load diagrams, click ok to run the tool.

When the tool finishes, a dialog will appear telling you what loads where considered, and if any loads where ignored. Select close to close the dialog.

Any load diagrams that where created will appear in the section drawing list, and the sections will be shown on the plans.

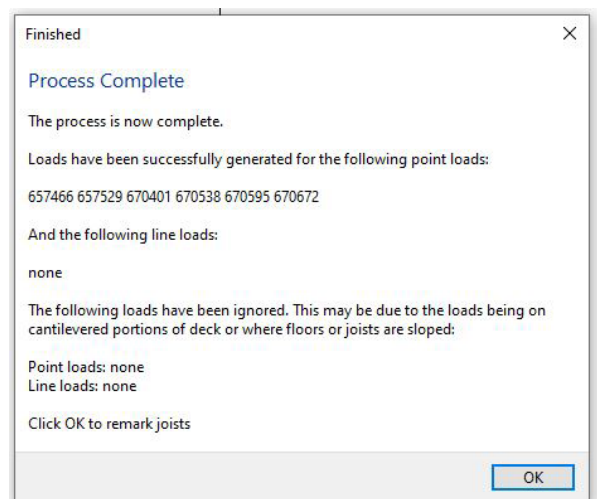
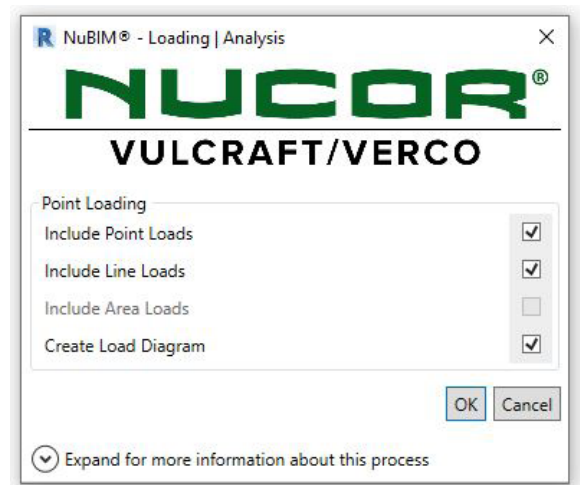
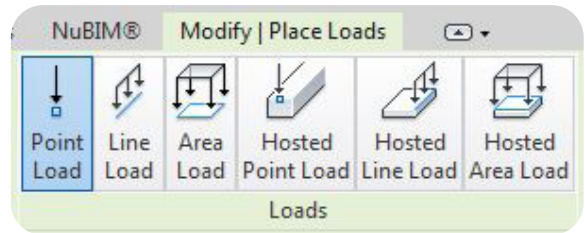
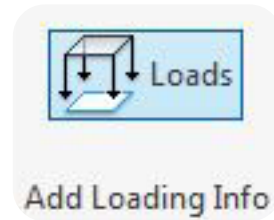

Joist Marking and Tagging will analyze the joists you have modeled and give similar joists the same mark. Joist designation, length, end conditions, slope, and loading are all considered when marking is performed. This allows you to quickly identify where different joists are located in the model.

To mark joists, go to the view you wish to tag the joists in, and select **Joist Marking and Tagging** from the tool ribbon. This will bring up the **Joist Tagging Options Dialog**:

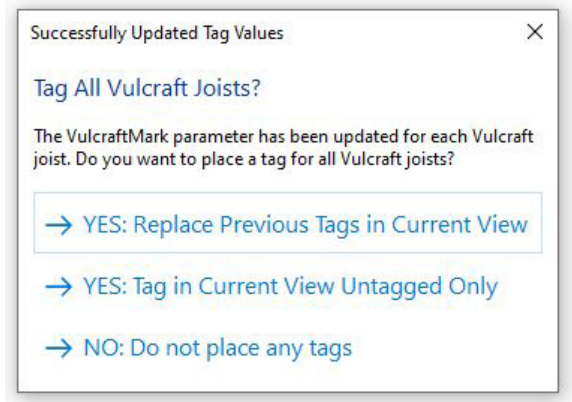

•YES: “Replace Previous Tags in Current View” will add/or update all the joist tags in the current view.

•YES: “Tag in Current View Untagged Only” will only tag un-tagged joists, any joist tags added previously will remain unchanged.

•NO: “Do not place any tags” will exit the Tagging Tool, and nothing in the model will be changed.

Note: *Joist Marking at specification may not match joist marking after Vulcraft/Verco detailing/engineering has occurred. Please use Vulcraft/Verco erection drawing marks.*

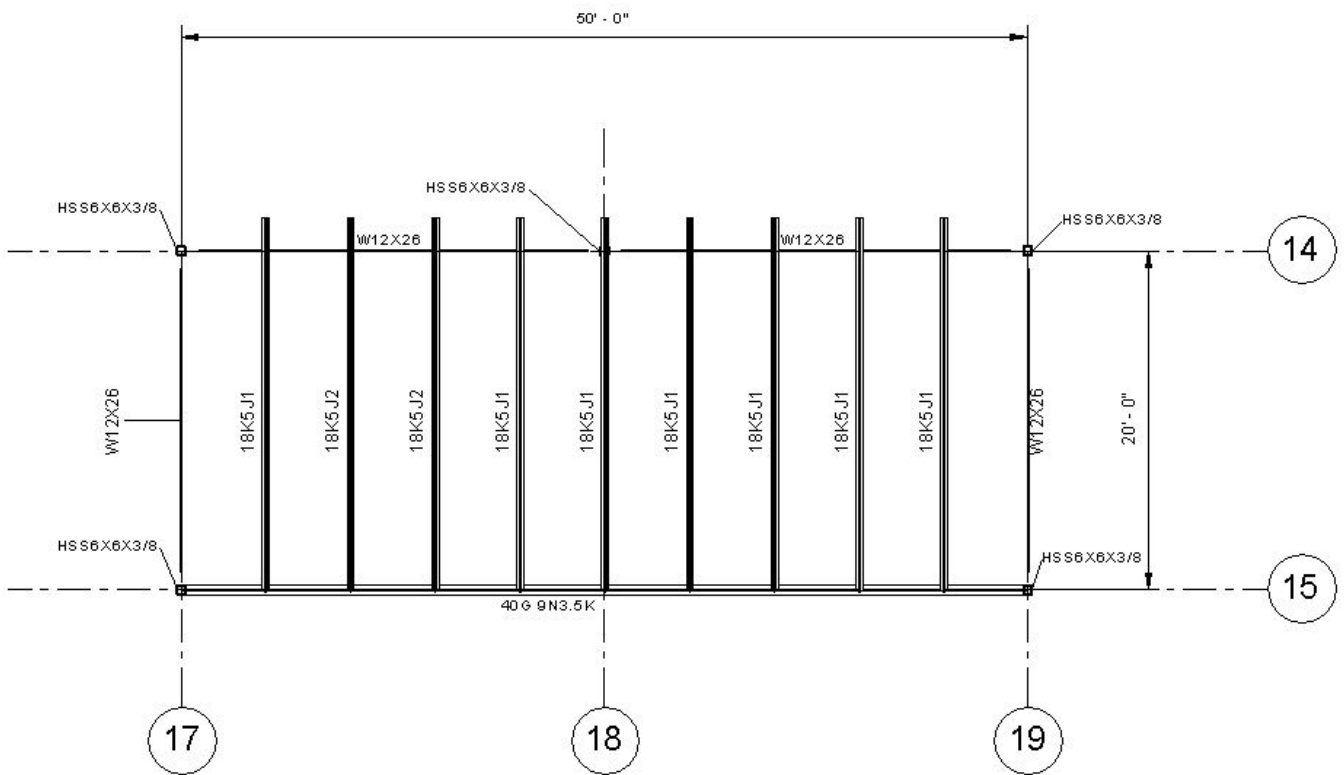

Tag Joist Ends allows you to add joist end information (TCX, BCX, Seat Depth) to your section views. This gives you the ability to cut live sections in your model, that will stay in sync with the model as you update it, eliminating the need to update stock section drawings.

To use the **Tag Joist Ends** tool, you must first be in a section view. After you have a section view open, select **Tag Joist Ends** to bring up the tool UI.

Once in the UI you will see the different options for **Joist End Tags**. You have the ability to turn the tags off and on for **End 1** and **End 2** of the joist independently.

The options for the types of tags include:

- **Top Chord Extension (TCX)** - Distance from reference line to end of top chord
- **Bottom Chord Extension (BCX)** - Distance from reference line to end of bottom chord
- **Seat Depth** - Depth of joist seat

You can also chose **Select All** to select all the end tags at once

Selecting **Update Tag Positions** will update the location of the tags if you have moved them or if the joist has changed and the tags no longer point to the correct location on the joist.

If you select **Tag Selected Joists Only**, only the joists you have selected will have tags placed on them. Otherwise all joists in the view will be tagged.

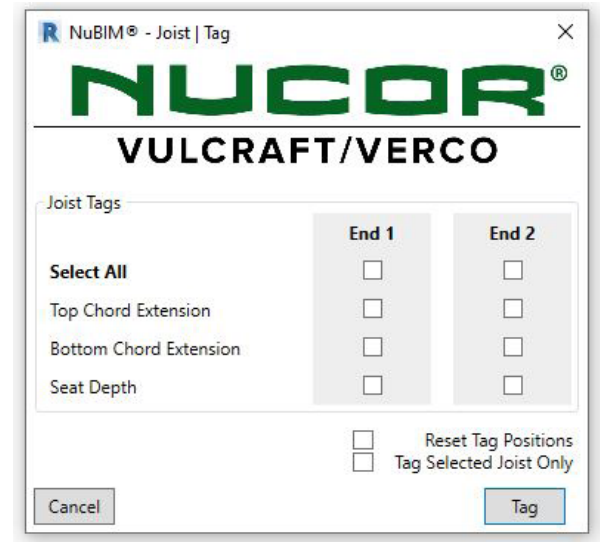

Once you have selected the tags you would like placed on the joist, click **Tag** to place the tags on the view.

The tags can be moved and adjusted just like any other tag in Revit.

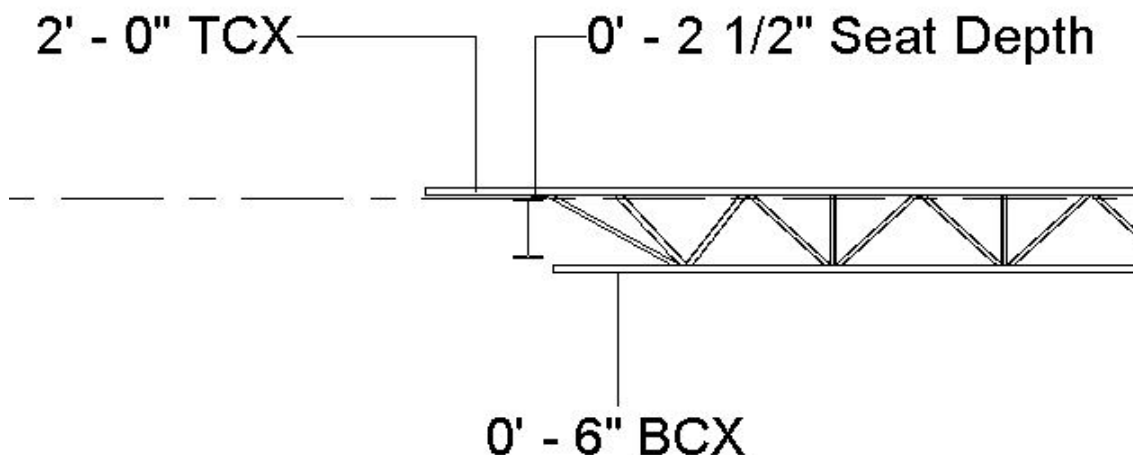

To use the **Match Properties Tool**, first select the tool from the tool ribbon. This will copy all joist properties, including series, profile, end conditions, and loading.

Then select the joist you wish to copy the properties from.

After you have selected the joist you wish to copy the properties from select the joist or joists you wish to copy the properties to.

(1.) To copy properties to multiple joists the multiple check-box must be checked.

(2.) When you are finished selecting the joists you would like the properties copied to, select **Finish** to update the joists.

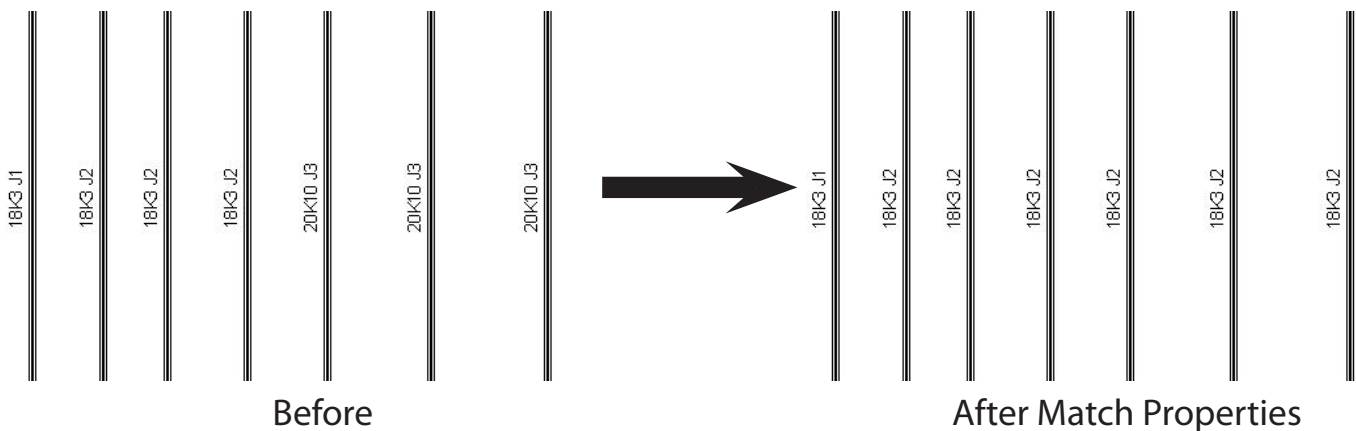
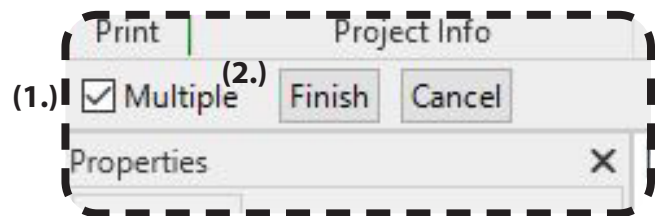
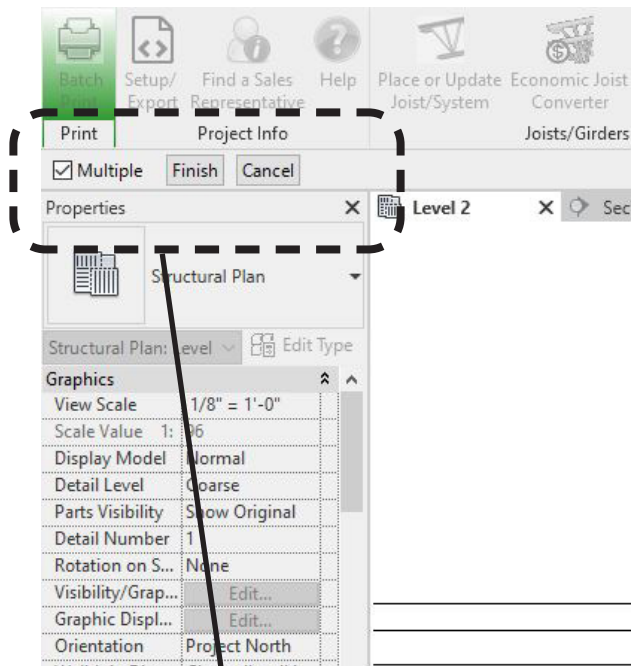



Deck Specification allows you to add Vulcraft or Verco deck profiles to standard Revit floor and roof assemblies. These profiles will show where section cuts are made through the model. In addition to the profile, deck gauge and finish can be specified.

Note: Both Roofs and Floors should be specified with the Structural Floor tool.

To specify deck you first must select whether you would like to use Vulcraft or Verco Profiles.

Vulcraft Profiles
 Verco Profiles

Then you can select what **Deck Type** you want to use: Roof, Non-Composite, or Composite

Deck Type:

 Profile Name:

 Gauge:

Next you select the **Profile Name** that is required.

Profile Name:

 Gauge:

 Finish Top:

 Type Name:

 Floor Thickness:

Then the **Gauge and Finish** can be specified. Only gauges and finishes are available for the given deck type to select. If something else is needed, please contact Vulcraft/Verco Sales.

Gauge: Galvanizing:

 Finish Top: Finish Bottom:

Note: Floor Thickness must be at minimum the depth of the Vulcraft/Verco profile selected, if the deck profile is to be shown in a section cut.

(1.) If the **Apply to Floor Type** check-box is un-checked the deck profile will simply be loaded into the model and can be selected in the Revit Floor Creation tool like any other profile. However, if the check box is left checked (default) you will be able to Create a New Floor Type or Apply the Profile to an Existing Floor Type.



(2.) If you **Create a New Type**, a suggested type name will auto-populate or you can input your own type name. You will also need to input a Floor Thickness at this time.

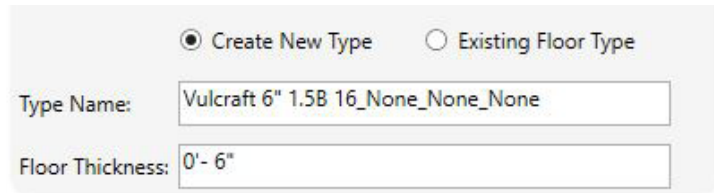

If you wish to apply the profile to an existing floor type you will need to select an existing floor type from the drop down list.

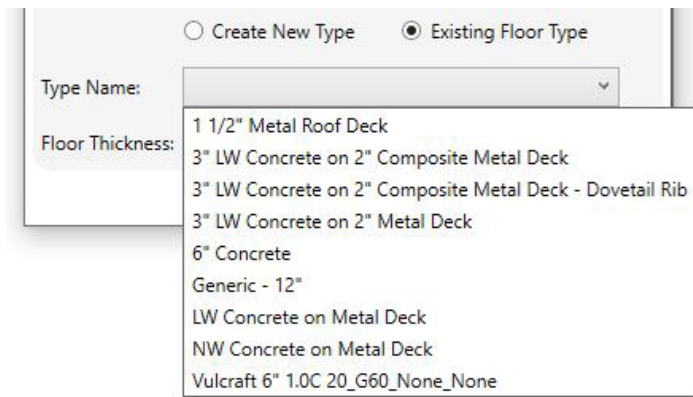

When you are finished click OK to either create the new floor type or apply the profile to an existing floor type. The floor type will then be able to be selected like any other floor type in Revit.

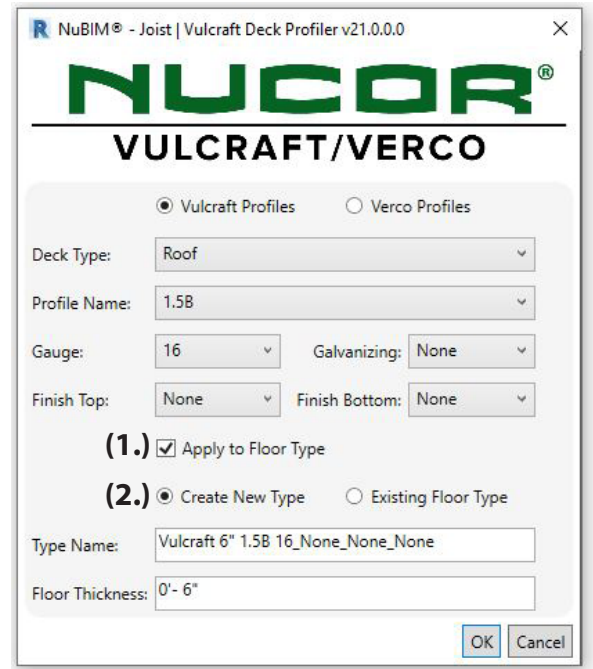

Actual Section Cuts:

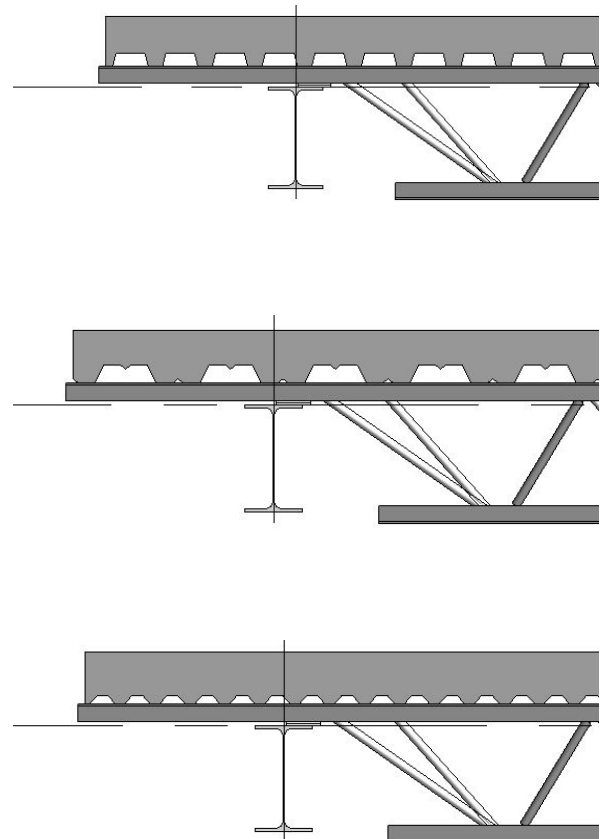

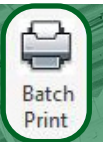

The **Batch Print** Tool allows you to create pdf files of your drawing sheets, similar to the stock Revit printer, but with a simpler UI and more automation.

Before using the **Batch Print** tool, you will need to have created drawing sheets. Created sheet sets is not required, but they can be created ahead of time or the tool itself allows you to create them.

First, you must set up your file settings.

- Select if you wish to create one single file with all sheets included, or individual files for each sheet.
- If separate files are desired you must set up the file naming logic. Some presets are built in (Sheet Number, Sheet Name, etc.), select the button at the end of the text box to select any desired presets. If any other text is required it can be typed into the box along with the presets.
- An output folder must also be selected. Select Browse to select an output folder.

The **Setup** section allows you to create and load sheet sets as well as change any parameters in the print setup.

To create **Sheet Sets**, select Create Sheet Sets to bring up the dialog. From here you can create new sheets sets or modify existing sheet sets.

Selecting **Load Sheet Sets** allows you to load any sheets you have created and assign the correct print setup to them at that time.

Once all the set up has been completed, all the sheets that have been loaded will show up in the **Print Range** section. From here you can select which sheets are to be printed, and what print setup you want for each sheet if different setups are required. The Batch Print tool will auto-select the paper size for you if you desire, and you may have different paper sizes selected for the same print session. The stock Revit printer does not allow this.

Once all of your selections have been made, select Print to create the files. All the pdfs will be saved in the folder you specified.

Within each of the individual sheet pdf files and xml file containing all the joist information for that sheet will be attached to the pdf. This can be provided to Vulcraft to aid in the quoting process.

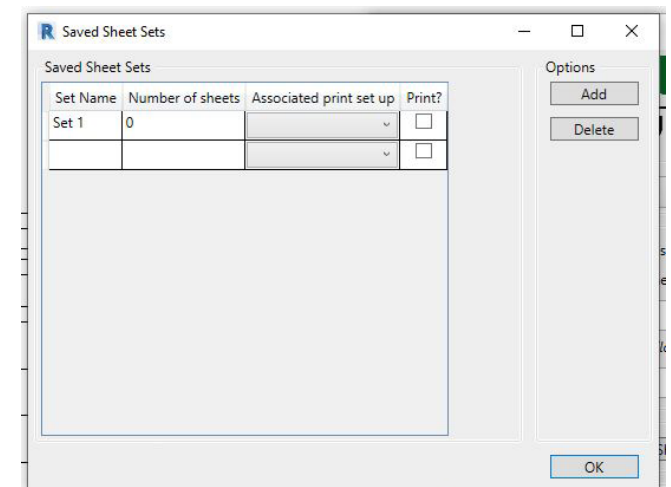
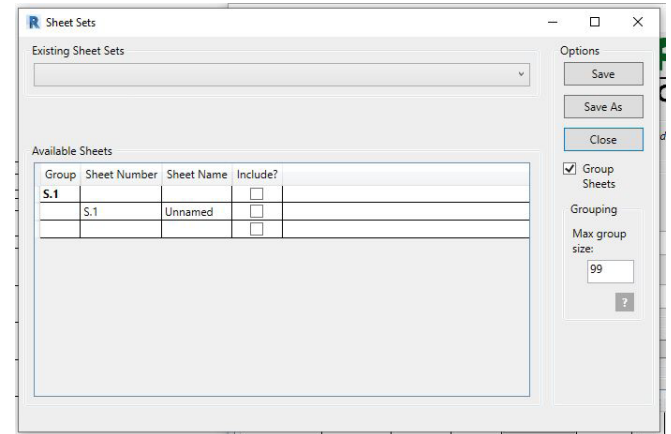
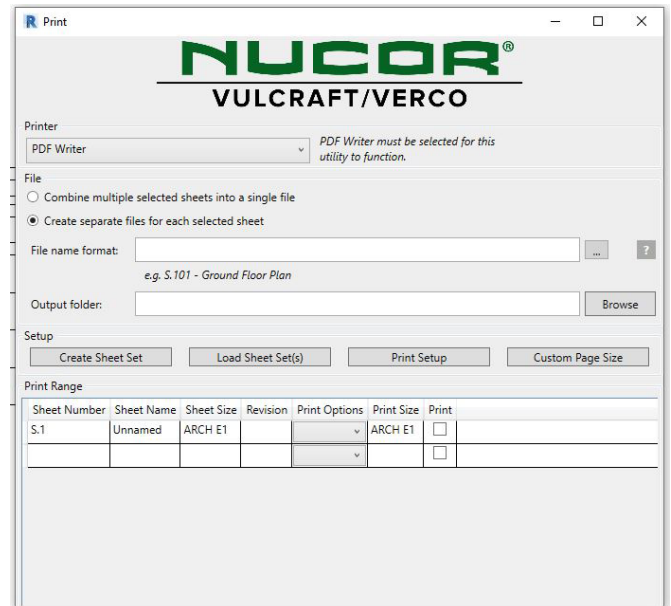

The **Job Setup/Export** tool will allow you to input additional information about the project, and export an XML file that Vulcraft can use to provide a fast and accurate quote for the project. (**Quote capability still under development. Please contact your local Vulcraft office for more information*)

Within the **Job Info** section you will be able to input the following information:

- Job Name
- Job Location (Zip Code)
- Contact Name
- Contact Email
- Contact Phone Number
- Vulcraft Sales Contact(Your Local Sales Rep)

Completing the information in these fields is not required, but highly recommended, as the information will help with future project coordination.

The **Job Specification** section allows you to input additional specification information relative to Vulcraft’s products. Vulcraft’s standard job specifications are set as defaults, but items such as Joist Finish, Joist Deflection, Bridging, and Design Type can be changed if required.

•**Additional Loads** can also be specified if **ALL** joists within the project need to be designed to support a specific load.

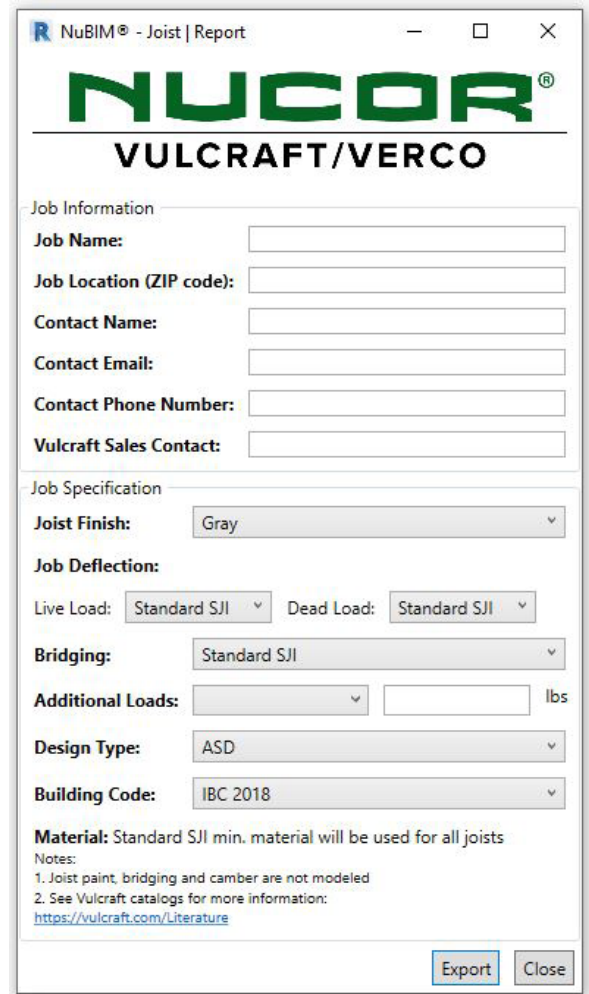

The screenshot shows a software window titled "NuBIM® - Joist | Report". The window contains the NUCOR logo and "VULCRAFT/VERCO" text. Below this, there are two main sections: "Job Information" and "Job Specification".

Job Information:

- Job Name: [Text Input]
- Job Location (ZIP code): [Text Input]
- Contact Name: [Text Input]
- Contact Email: [Text Input]
- Contact Phone Number: [Text Input]
- Vulcraft Sales Contact: [Text Input]

Job Specification:

- Joist Finish: [Dropdown Menu] (Selected: Gray)
- Job Deflection: [Text Input]
- Live Load: [Dropdown Menu] (Selected: Standard SJI) | Dead Load: [Dropdown Menu] (Selected: Standard SJI)
- Bridging: [Dropdown Menu] (Selected: Standard SJI)
- Additional Loads: [Dropdown Menu] | [Text Input] lbs
- Design Type: [Dropdown Menu] (Selected: ASD)
- Building Code: [Dropdown Menu] (Selected: IBC 2018)

Material: Standard SJI min. material will be used for all joists

Notes:

- Joist paint, bridging and camber are not modeled
- See Vulcraft catalogs for more information: <https://vulcraft.com/Literature>

Buttons: [Export] [Close]

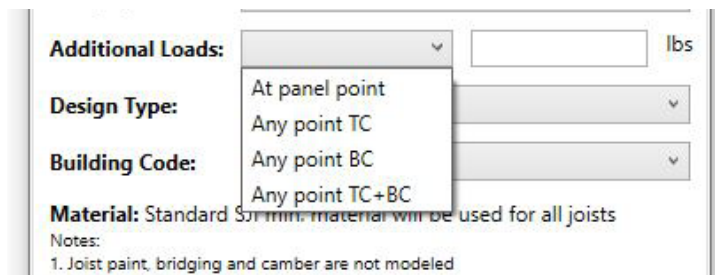

This close-up shows the "Additional Loads" field with a dropdown menu open, listing options: "At panel point", "Any point TC", "Any point BC", and "Any point TC+BC". Below it, the "Design Type" and "Building Code" fields are also visible with dropdown menus.

Material: Standard SJI min. material will be used for all joists

Notes:

- Joist paint, bridging and camber are not modeled

Design Type and Building Code can also be specified.

When all the desired information is input, select Export to create the XML file that can then be sent to Vulcraft for Project Quoting and Coordination.

If you are using the tool for the first time, the Job Setup dialog will appear when you first use one of our tools, any data that is input will be saved so that it does not need to be re-input later on.

ADDITIONAL FEATURES



FIND A SALES REPRESENTATIVE

Selecting the **Find a Sales Representative** tool will take you to the Vulcraft/Verco Website and allow you to locate your nearest Sales Office based on your location or your project location.



HELP

Selecting the **Help** tool will take you to the Vulcraft/Verco Website and allow you to access the most current trouble shooting information. You can also visit <https://vulcraft.com/DesignTools/RevitDownloads>



LOAD FAMILIES

Selecting the **Load Families** tool will take you to the folder on your computer that contains our Joist and Deck Families. This will allow you to use our families without the tool if you choose. It is recommend that if you intend to use the families without the tool that you copy the families to another location. This is especially important if you intend to make any modification to the families. Doing this will prevent any issues with the tool if, in the future, you decide to use the original families with the too.

For Additional Questions Regarding
Vulcraft's NuBIM® Add-in Please Contact:
BIM@vulcraft.com