

VULCRAFT®

BRIDGING GUIDE

BASED ON SJI SPECS 45TH EDITION



American National Standard SJI 100 - 2015

TABLE 5.5-1

U.S. CUSTOMARY UNITS										
NUMBER OF ROWS OF TOP CHORD BRIDGING ²										
Section Number ¹	Joist Depth	1 Row	2 Rows	3 Rows	4 Rows	5 Rows	6 Rows	7 Rows	8 Rows	9 Rows
K1	All	17	>17 to 26	>26 to 28						
K2	All	21	>21 to 30	>30 to 32						
K3	All	18	>18 to 26	>26 to 40						
K4	All	20	>20 to 30	>30 to 41	>41 to 48					
K5	12K to 24K	20	>20 to 30	>30 to 42	>42 to 48					
	26K	28	>28 to 41	>41 to 52						
K6	14K to 24K	20	>20 to 31	>31 to 42	>42 to 48					
	26K & 28K	28	>28 to 41	>41 to 54	>54 to 56					
K7	16K to 24K	23	>23 to 34	>34 to 48						
	26K to 30K	29	>29 to 44	>44 to 60						
K8	24K	25	>25 to 39	>39 to 48						
	26K to 30K	29	>29 to 44	>44 to 60						
K9	16K to 24K	22	>22 to 34	>34 to 48						
	26K to 30K	29	>29 to 44	>44 to 60						
K10	18K to 24K	22	>22 to 38	>38 to 48						
	26K to 30K	29	>29 to 48	>48 to 60						
K11	22K	24	>24 to 39	>39 to 44						
	30K	34	>34 to 49	>49 to 60						
K12	24K	25	>25 to 43	>43 to 48						
	26K to 30K	29	>29 to 47	>47 to 60						
LH02-03	All	20	>20 to 30	>30 to 40	>40					
LH04-05	All	22	>22 to 33	>33 to 44	>44 to 55	>55				
LH06-08	All	26	>26 to 45	>45 to 60	>60 to 75	>75				
LH09	All	26	>26 to 48	>48 to 64	>64 to 80	>80				
LH/DLH10	All	28	>28 to 54	>54 to 72	>72 to 90	>90				
LH/DLH11	All	30	>30 to 54	>54 to 72	>72 to 90	>90 to 108	>108			
LH/DLH12	All	34	>34 to 55	>55 to 74	>74 to 92	>92 to 111	>111			
LH/DLH13	All	36	>36 to 63	>63 to 84	>84 to 105	>105 to 126	>126			
LH/DLH14	All	38	>38 to 64	>64 to 86	>86 to 107	>107 to 129	>129			
LH/DLH15	All	42	>42 to 73	>73 to 98	>98 to 122	>122 to 147	>147			
LH/DLH 16-17	All	44	>44 to 75	>75 to 100	>100 to 125	>125 to 150	>150 to 175	>175		
DLH18-20	All	52	>52 to 78	>78 to 104	>104 to 130	>130 to 156	>156 to 182	>182 to 208	>208 to 234	>234
DLH21-25	All	60	>60 to 90	>90 to 120	>120 to 150	>150 to 180	>180 to 210	>210		

(1) Last digit(s) of joist designation shown in Load Table.
 (2) Distances are Joist Span lengths in feet – See “Definition of Span” Figure 5.2-1. Refer to the Joist Load Table and Specification Section 6 for required bolted diagonal bridging and additional stability requirements. See Section 5.12 for additional bridging required for uplift design.



Bridging Requirements of LH-Series Joists
 Erection Stability Spans (SJI Spec. Section 105)

Depth	Section Number*	Spans Greater Than**	Depth	Section Number*	Spans Greater Than**
18	02	33'	32	06 thru 07	47'
	03 thru 09	37'		08	55'
20	02	33'		09 thru 15	60'
	03	38'	36	07 thru 08	47'
04 thru 10	41'	09		57'	
24	03	35'	10 thru 15	60'	
	04	39'	40	08 thru 09	47'
	05	40'		10 thru 17	60'
	06	45'	44	09	52'
07 thru 11	49'	10 thru 17		60'	
28	05	42'	48	10 thru 17	60'
	06	46'			
	07 thru 08	54'			
	09 thru 13	57'			

* Last two digits of joist designation.

** NOTE: For spans EQUAL TO OR EXCEEDING that shown, one of the rows nearest mid-span must be bolted diagonal type. For spans through 60 feet, the bolted diagonal bridging must be installed BEFORE releasing the hoisting lines. FOR SPANS OVER 60 FEET, ALL BRIDGING ROWS MUST BE BOLTED DIAGONAL TYPE. Spans over 60 feet through 100 feet require two rows of bolted diagonal bridging to be installed, at one-third points, BEFORE releasing the hoisting lines. Spans over 100 feet require ALL rows of bolted diagonal bridging to be installed BEFORE releasing the hoisting lines.

TABLE 2.7-1

MAXIMUM JOIST SPACING FOR HORIZONTAL BRIDGING							
SPANS OVER 60 ft. (18.3 m) REQUIRE BOLTED DIAGONAL BRIDGING							
JOIST SECTION NUMBER ¹	Nominal Unfactored Force P _{br} lbs (N)	BRIDGING MATERIAL SIZE ²					
		Equal Leg Angles					
		1 x 7/64 (25 x 3 mm) r = 0.20" (5.08 mm)	1-1/4 x 7/64 (32 x 3 mm) r = 0.25" (6.35 mm)	1-1/2 x 7/64 (38 x 3 mm) r = 0.30" (7.62 mm)	1-3/4 x 7/64 (45 x 3 mm) r = 0.35" (8.89 mm)	2 x 1/8 (52 x 3 mm) r = 0.40" (10.16 mm)	2-1/2 x 5/32 (64 x 4 mm) r = 0.50" (12.70 mm)
		ft.-in. (mm)	ft.-in. (mm)	ft.-in. (mm)	ft.-in. (mm)	ft.-in. (mm)	ft.-in. (mm)
K1 – 8	340 (1512)	5'-0" (1524)	6'-3" (1905)	7'-6" (2286)	8'-9" (2667)	10'-0" (3048)	12'-6" (3810)
K9-10, LH02-03	450 (2002)	4'-4" (1321)	6'-1" (1854)	7'-6" (2286)	8'-9" (2667)	10'-0" (3048)	12'-6" (3810)
K11-12, LH04-05	560 (2491)	3'-11" (1194)	5'-6" (1676)	7'-4" (2235)	8'-9" (2667)	10'-0" (3048)	12'-6" (3810)
LH06-08	750 (3336)		4'-9" (1448)	6'-3" (1905)	7'-11" (2413)	10'-0" (3048)	12'-6" (3810)
LH09	850 (3781)		4'-5" (1346)	5'-10" (1778)	7'-5" (2261)	9'-9" (2972)	12'-6" (3810)
LH/DLH10	900 (4003)		4'-4" (1321)	5'-8" (1727)	7'-3" (2210)	9'-5" (2870)	12'-6" (3810)
LH/DLH11	950 (4226)		4'-2" (1270)	5'-7" (1702)	7'-0" (2134)	9'-2" (2794)	12'-6" (3810)
LH/DLH12	1100 (4893)		3'-11" (1194)	5'-2" (1575)	6'-8" (2032)	8'-6" (2591)	12'-6" (3810)
LH/DLH13	1200 (5338)		3'-9" (1143)	4'-11" (1499)	6'-3" (1905)	8'-2" (2489)	12'-6" (3810)
LH/DLH14	1300 (5783)			4'-9" (1448)	6'-0" (1829)	7'-10" (2388)	12'-4" (3759)
LH/DLH15	1450 (6450)			4'-6" (1372)	5'-8" (1727)	7'-5" (2261)	11'-8" (3556)
LH/DLH16-17	1850 (8229)			4'-0" (1219)	5'-0" (1524)	6'-7" (2007)	10'-4" (3150)
DLH18-20	2350 (10453)			3'-7" (1067)	4'-4" (1321)	5'-10" (1778)	9'-1" (2769)
DLH21-22	3150 (14012)				3'-10" (1168)	5'-0" (1524)	7'-11" (2413)
DLH23-24	4130 (18371)				3'-4" (1016)	4'-5" (1346)	6'-11" (2108)
DLH25	4770 (21218)					4'-1" (1245)	6'-5" (1956)

(1) Refer to last two digit(s) of Joist Designation

(2) Connection to joist shall resist force listed in the Steel Joist Institute Standard Specifications Table 5.5-2



TABLE 2.7-3

K, LH, and DLH SERIES JOISTS
MAXIMUM JOIST SPACING FOR DIAGONAL BRIDGING

JOIST DEPTH	BRIDGING ANGLE SIZE – (EQUAL LEG ANGLE)							
	1 x 7/64 (25 x 3 mm) r = 0.20" (5.08 mm)	1-1/4 x 7/64 (32 x 3 mm) r = 0.25" (6.35 mm)	1-1/2 x 7/64 (38 x 3 mm) r = 0.30" (7.62 mm)	1-3/4 x 7/64 (45 x 3 mm) r = 0.35" (8.89 mm)	2 x 1/8 (50 x 3 mm) r = 0.40" (10.16 mm)	2 1/2 x 5/32 (64 x 4 mm) r = 0.50" (12.70 mm)	3 x 3/16 (76 x 5 mm) r = 0.60" (15.24 mm)	3 1/2 x 1/4 (89 x 6 mm) r = 0.70" (17.78 mm)
	in. (mm)	ft.-in. (mm)	ft.-in. (mm)	ft.-in. (mm)	ft.-in. (mm)	ft.-in. (mm)	ft.-in. (mm)	ft.-in. (mm)
12" (305)	6'-7" (2007)	8'-3" (2514)	9'-11"(3022)	11'-7" (3530)	13'-3"(4038)	16'-7"(5055)	19'-11"(6070)	23'-3"(7086)
14" (356)	6'-6" (1981)	8'-3" (2514)	9'-11"(3022)	11'-7" (3530)	13'-3"(4038)	16'-7"(5055)	19'-11"(6070)	23'-3"(7086)
16" (406)	6'-6" (1981)	8'-2" (2489)	9'-10"(2997)	11'-7" (3530)	13'-3"(4038)	16'-7"(5055)	19'-11"(6070)	23'-3"(7086)
18" (457)	6'-6" (1981)	8'-2" (2489)	9'-10"(2997)	11'-6" (3505)	13'-3"(4038)	16'-7"(5055)	19'-11"(6070)	23'-3"(7086)
20" (508)	6'-5" (1955)	8'-2" (2489)	9'-10"(2997)	11'-6" (3505)	13'-2"(4013)	16'-7"(5055)	19'-11"(6070)	23'-3"(7086)
22" (559)	6'-4" (1930)	8'-1" (2463)	9'-10"(2997)	11'-6" (3505)	13'-2"(4013)	16'-6"(5029)	19'-11"(6070)	23'-3"(7086)
24" (610)	6'-4" (1930)	8'-1" (2463)	9'-9" (2971)	11'-5" (3479)	13'-2"(4013)	16'-6"(5029)	19'-10"(6045)	23'-3"(7086)
26" (660)	6'-3" (1905)	8'-0" (2438)	9'-9" (2971)	11'-5" (3479)	13'-1"(3987)	16'-6"(5029)	19'-10"(6045)	23'-2"(7061)
28" (711)	6'-3" (1905)	8'-0" (2438)	9'-8" (2946)	11'-5" (3479)	13'-1"(3987)	16'-6"(5029)	19'-10"(6045)	23'-2"(7061)
30" (762)	6'-2" (1879)	7'-11" (2413)	9'-8" (2946)	11'-4" (3454)	13'-1"(3987)	16'-5"(5004)	19'-10"(6045)	23'-2"(7061)
32" (813)	6'-1" (1854)	7'-10"(2387)	9'-7" (2921)	11'-4" (3454)	13'-0" (3962)	16'-5"(5004)	19'-9"(6020)	23'-2"(7061)
36" (914)	5'-11"(1803)	7'-9" (2362)	9'-6" (2895)	11'-3" (3429)	12'-11"(3973)	16'-4"(4979)	19'-9"(6020)	23'-1"(7035)
40" (1016)	5'-9"(1753)	7'-7" (2311)	9'-5" (2870)	11'-2" (3403)	12'-10"(3911)	16'-4"(4979)	19'-8"(5994)	23'-1"(7035)
44" (1118)	5'-6"(1676)	7'-5" (2260)	9'-3" (2819)	11'-0" (3352)	12'-9" (3886)	16'-3"(4953)	19'-7"(5969)	23'-0"(7010)
48" (1219)	5'-4"(1626)	7'-3" (2209)	9'-2" (2794)	10'-11"(3327)	12'-8" (3860)	16'-2"(4928)	19'-7"(5969)	22'-11"(6985)
52" (1321)	5'-0"(1524)	7'-1"(2159)	9'-0" (2743)	10'-10" (3302)	12'-7" (3835)	16'-1"(4902)	19'-6"(5943)	22'-11"(6985)
56" (1422)	4'-9"(1448)	6'-10"(2083)	8'-10"(2692)	10'-8" (3251)	12'-5" (3784)	16'-0"(4877)	19'-5"(5918)	22'-10"(6960)
60" (1524)	4'-4"(1321)	6'-8"(2032)	8'-7" (2616)	10'-6" (3200)	12'-4" (3759)	15'-10"(4826)	19'-4"(5893)	22'-9"(6935)
64" (1626)	**	6'-4"(1931)	8'-5" (2565)	10'-4" (3149)	12'-2" (3708)	15'-9" (4801)	19'-3"(5867)	22'-8"(6909)
68" (1727)	**	6'-1"(1854)	8'-2" (2489)	10'-2" (3098)	12'-0" (3657)	15'-8" (4775)	19'-2"(5842)	22'-7"(6884)
72" (1829)	**	5'-9"(1753)	8'-0" (2438)	10'-0" (3048)	11'-10"(3606)	15'-6" (4724)	19'-1" (5816)	22'-6" (6858)
80" (2032)	**	5'-0"(1524)	7'-5"(2260)	9'-6" (2895)	11'-6" (3505)	15'-3" (4648)	18'-10"(5740)	22'-4" (6808)
88" (2235)	**	**	6'-9"(2058)	9'-0" (2743)	11'-1" (3378)	14'-11"(4546)	18'-7" (5664)	22'-1" (6731)
96" (2438)	**	**	6'-0"(1829)	8'-5" (2565)	10'-8"(3251)	14'-7" (4445)	18'-4" (5588)	21'-11"(6680)
104" (2642)	**	**	**	7'-9" (2362)	10'-1"(3073)	14'-2" (4318)	18'-0" (5486)	21'-8" (6604)
112" (2845)	**	**	**	7'-0" (2134)	9'-6"(2895)	13'-9" (4191)	17'-8" (5385)	21'-4" (6503)
120" (3048)	**	**	**	**	8'-9"(2667)	13'-4"(4064)	17'-3" (5258)	21'-1" (6426)

**INTERPOLATION BELOW THE MINIMUM VALUES SHOWN IS NOT ALLOWED.
SEE TABLE 2.7-4 FOR MINIMUM JOIST SPACE FOR DIAGONAL ONLY BRIDGING.

BRIDGING DETAILS

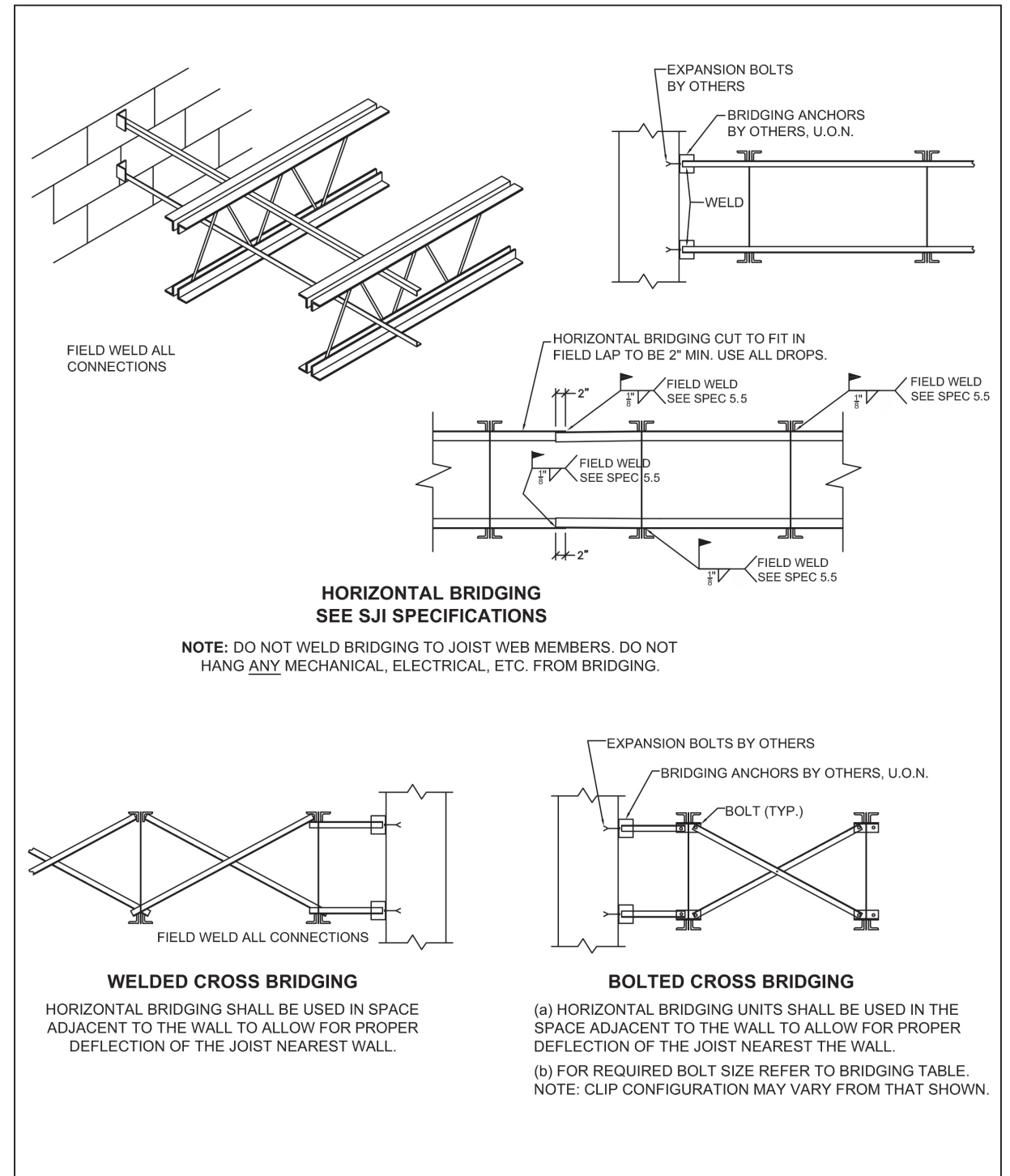

VULCRAFT SALES CORPORATION OFFICES

ATLANTA, GA
P. 770.307.2111

GRAND RAPIDS, MI
P. 616.949.2106

NORRISTOWN, PA
P. 610.539.6516

BALTIMORE, MD
P. 410.998.0800

HINSDALE, IL
P. 630.887.1400

OKLAHOMA CITY, OK
P. 405.715.2844

BIRMINGHAM, AL
P. 205.982.4394

HOUSTON, TX
P. 281.251.8857

ORANGE, CA
P. 714.957.5713

BOARDMAN, OH
P. 330.726.8833

INDIANAPOLIS, IN
P. 317.576.5399

OVERLAND PARK, KS
P. 913.341.9299

CENTERVILLE, UT
P. 801.292.0730

KERNSVILLE, NC
P. 336.497.5302

PHOENIX, AZ
P. 623.385.1649

COLUMBIA, SC
P. 803.358.1300

KNOXVILLE, TN
P. 865.690.6388

SACRAMENTO, CA
P. 916.488.8180

DALLAS, TX
P. 214.340.1883

LEXINGTON, KY
P. 859.940.0152

SALEM, NH
P. 603.894.1146

DENVER, CO
P. 303.757.6323

LITTLE ROCK, AR
P. 501.758.6424

SAN ANTONIO, TX
P. 210.655.9070

EDISON, NJ
P. 732.738.8188

MEMPHIS, TN
P. 901.612.3481

SEATTLE, WA
P. 425.402.9011

FLOWOOD, MS
P. 601.383.7807

MINNEAPOLIS, MN
P. 763.425.4399

SPRINGFIELD, OH
P. 937.390.2300

GENEVA, NY
P. 315.828.1730

NASHVILLE, TN
P. 615.871.9385

ST. LOUIS, MO
P. 636.266.1844

GERMANTOWN, WI
P. 262.251.5666

NEW HUDSON, MI
P. 248.486.6166

TAMPA, FL
P. 813.621.0684

Please Visit the **Contact Us** Page at www.Vulcraft.com to Find Your Closest Sales Office