



NUCOR CORPORATION - VULCRAFT/VERCO GROUP

VULCRAFT GROUP

7205 Gault Avenue North
Fort Payne, Alabama 35967
(256) 845-2460
www.vulcraft.com

VERCO DECKING, INC. a NUCOR Company

4340 North 42nd Avenue
Phoenix, Arizona 85019
(602) 272-1347
www.vercodeck.com

STEEL DECK PANELS

CSI DIVISION: 05 00 00 – METALS

CSI SECTION: 05 31 00 – STEEL DECK

05 31 13 – STEEL FLOOR DECKING

05 31 23 – STEEL ROOF DECKING

1.0 RECOGNITION

Steel deck recognized in this report has been evaluated for use as a component of horizontal or sloped floor and roof systems supporting out of plane loads, in-plane diaphragm shears, and in-plane axial loads. Physical characteristic and structural performance properties comply with the intent of the provisions of the following codes and regulations:

- 2018, 2015 and 2012 International Building Code® (IBC)
- 2018, 2015 and 2012 International Residential Code® (IRC)
- 2019, 2016 California Building Code (CBC)
- 2017 City of Los Angeles Building Code (LABC)
- 2017 City of Los Angeles Residential Code (LARC)

2.0 LIMITATIONS

Use of the steel deck recognized in this report is subject to the following limitations:

2.1 Sound Transmission Performance: Acoustic performance is beyond the scope of this report.

2.2 Fire-Resistance Ratings: Fire-resistance performance is beyond the scope of this report.

2.3 The products described in this report shall be installed in accordance with the applicable code, the manufacturer's published installation instructions, and this report. Where there is a conflict, the most restrictive requirements shall govern.

2.4 The steel panels recognized in this report are produced by Vulcraft in Fort Payne, Alabama.

3.0 PRODUCT USE

3.1 General:

It is permissible to use steel deck panels to resist out-of-plane loads, in plane diaphragm shear loads, and axial loads.

3.2 Design:

3.2.1 Out-of-Plane Strength: Out-of-plane strength of deck panels shall be determined using engineering mechanics and deck panel properties presented in this report.

Deflections resulting from out-of-plane load shall comply with Section 1604.3 of the IBC.

3.2.2 Composite Steel Deck-Slabs: Composite steel deck-slab out-of-plane load strength (superimposed loads) shall be determined in accordance with ANSI/SDI C-2017 using properties and composite coefficients in this report. In accordance with ACI 318-14 26.4.1.4.1(c) or ACI 318-11 3.6.4, calcium chloride or admixtures containing chloride from sources other than impurities in admixture ingredients are prohibited from use in concrete cast against stay-in-place galvanized steel deck.

3.2.3 Reactions: The strength of steel deck panels to resist reaction loads at supports and locations of concentrated loads shall be determined based on the either web crippling strength or web shear strength. Web crippling strength shall be determined in accordance with AISI S100-16 Section G5 and the properties in this report. Deck panel web shear strength of deck panel webs shall be determined in accordance with AISI S100-16 Section G2.1 and the properties in this report. The strength of web-perforated deck panels shall be determined in accordance with the equations in this report.

3.2.4 In-Plane (Diaphragm) Shear Strength and Stiffness: The in-plane shear strength of steel roof deck, non-composite steel deck, or composite steel deck-slabs shall be determined in accordance with AISI S310-16 including the modifications and properties in this report.

3.2.5 Axial Strength: The axial strength or combined axial and bending strength of steel deck panels shall be determined in accordance with AISI S100-16 using the properties in this report.

3.2.6 Wall Bracing: The design for anchorage of structural walls and transfer of anchorage forces into the diaphragm shall be in accordance with Section 12.11.2 of ASCE/SEI 7, subject to the following limitations:



1. Transfer of anchorage forces into diaphragm shall be in the direction parallel to the flutes (ribs) of the steel deck.

2. When acting as the continuous ties or struts between diaphragm chords, anchorage forces shall be distributed into the diaphragm in the direction parallel to the flutes (ribs) of the steel deck.

3. Combined axial load and bending shall be considered in accordance with Section H1 of AISI S100-16 to determine the strength of steel deck (without concrete fill) used to resist wall anchorage forces or to resist continuous tie forces parallel to the flutes (ribs).

4. Power-actuated fasteners, self-drilling screws, or welded connections described in this report are permitted to provide positive means of attachment to satisfy the connection requirements in ASCE/SEI 7 Section 12.11.2.2.1.

3.2.7 Partial Panels, Openings, Holes or Penetrations through Steel Deck: The registered design professional may submit design calculations and details to the building official for approval based on the principles of engineering mechanics for partial panels, openings, holes or penetrations. For lateral force resisting systems, the calculations shall consider the effects of partial panels, openings, holes, or penetrations on the overall strength and stiffness of the diaphragm.

3.2.8 Supporting Member Materials: Supporting members shall comply with the requirements of AISI S310-16.

3.2.9 Connections:

3.2.9.1 Self-Drilling Screws: Self-drilling screws may be used to attach steel deck panels to supporting members and to attach the sidelaps of steel deck panels to each other in accordance with AISI S100 and AISI S310 unless described in this report. The screws shall be manufactured in accordance with SAE J78 and shall be compliant with ASTM C1513.

3.2.9.2 Power Actuated Fasteners (PAF's): Power actuated fasteners may be used to attach steel deck panels to supporting members in accordance with this report. The fasteners shall be designed to attach steel deck panels to supporting members and shall be described in a current evaluation report issued by an approved and accredited evaluation service.

3.2.9.3 Welds: Welds may be used to attach steel deck panels to supporting members and to attach the sidelaps of steel deck panels to each other in accordance with AISI S100-16 and AISI S310-16. The minimum tensile strength of the weld filler shall be designated as a minimum of 60 ksi (413.7 MPa) and comply with the appropriate AWS standard.

3.3 Installation:

Steel deck panel erection sequence and installation method is the responsibility of the contractor(s) performing installation of the steel deck panels. Installation shall be in accordance with this report, ANSI/SDI RD-2017, ANSI/SDI NC-2017 and ANSI/SDI C-2017 and all welds shall comply with AWS D1.3. Where conflicts occur, the more restrictive shall govern. Additional installation information is available in the Steel Deck Institute (SDI MOC) Manual of Construction with Steel Deck and manufacturer's recommendations. Mechanical fasteners shall be installed in accordance with the manufacturer's current evaluation report issued by an approved and accredited evaluation service. Quality control during installation shall comply with ANSI/SDI QA/QC.

3.4 Inspections:

3.4.1 General: Special inspection is required in accordance with IBC Chapter 17. Quality assurance for deck installation shall comply with ANSI/SDI QA/QC, where the special inspector duties are as set forth for the quality assurance inspector (QAI).

3.4.2 Jobsite Welding: Periodic special inspection for welding shall be in accordance with IBC Section Chapter 17. Prior to proceeding, the welder shall demonstrate the ability to produce the prescribed weld to the special inspector's satisfaction. The inspector's duties include verification of materials, weld preparation, welding procedures, and welding processes.

3.4.3 Concrete: Continuous and periodic special inspection for concrete and concrete reinforcement shall be in accordance with Section 1705.3 of the IBC. The inspector's duties include sampling and testing, and verification of concrete mixes, reinforcement types and placement, and concrete placement.

3.4.4 Periodic Special Inspection: Periodic special inspections for weld, screw and power-actuated fastener connections are required where the steel deck systems are used in a seismic-force-resisting system in structures assigned to Seismic Design Category C, D, E or F; or a wind-force resisting system in areas described in IBC Chapter 17.



4.0 PRODUCT DESCRIPTION

4.1 Steel Deck Panels: The steel deck panels described in this report are cold-formed from steel sheets into panels with fluted sections. Panel characteristics including profile designation, sidelap type, applicable sidelap fasteners and perforations for fluted profiles are described in the tables and figures that accompany this report.

The galvanized deck panels are formed from either ASTM A653 or A1063 steel, with a minimum G30 galvanized coating designation.

Vulcraft® is a registered trademark of Nucor Corporation or its affiliates.

4.2 Concrete: Concrete shall be either lightweight concrete or normal weight concrete and comply with Chapter 19 of the IBC. In accordance with ACI 318-14 26.4.1.4.1(c) or ACI 318-11 3.6.4, calcium chloride or admixtures containing chloride from sources other than impurities in admixture ingredients are prohibited from use in concrete cast against stay-in-place galvanized steel deck or embedded items. The minimum compressive strength shall be as indicated in the tables and figures of this report.

5.0 IDENTIFICATION

Each bundle of deck panels is identified with a visible label. The label includes the manufacturer's name (Vulcraft), production location (Alabama) and address, evaluation report number, deck type, steel specification, base metal thickness and gage, one of the IAPMO ES Marks of Conformity noted below, and evaluation report number (ER-0423).

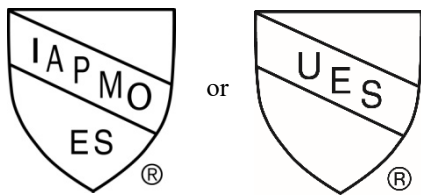

IAPMO UES ER-0423

6.0 SUBSTANTIATING DATA

Data in accordance with the IAPMO Uniform Evaluation Service Evaluation Criteria EC-007, Adopted April 2019, Evaluation Criteria for Steel Composite, Non-composite, and Roof Deck Construction.

7.0 STATEMENT OF RECOGNITION

This evaluation report describes the results of research carried out by IAPMO Uniform Evaluation Service on Vulcraft steel deck panels to assess conformance to the codes shown in Section 1.0 of this report and serves as documentation of the product certification. Products are manufactured at locations noted in Section 2.4 of this report under a quality control program with periodic inspection under the supervision of IAPMO UES.

Brian Gerber, P.E., S.E.
Vice President, Technical Operations
Uniform Evaluation Service

Richard Beck, PE, CBO, MCP
Vice President, Uniform Evaluation Service

GP Russ Chaney
CEO, The IAPMO Group

For additional information about this evaluation report please visit www.uniform-es.org or email at info@uniform-es.org



CALIFORNIA SUPPLEMENT

REPORT HOLDER

NUCOR CORPORATION -
VULCRAFT/VERCO GROUP

VULCRAFT GROUP

7205 Gault Avenue North
Fort Payne, Alabama 35967
(256) 845-2460
www.vulcraft.com

VERCO DECKING, INC. a NUCOR Company

4340 North 42nd Avenue
Phoenix, Arizona 85019
(602) 272-1347
www.vercodeck.com

STEEL DECK PANELS

CSI Section: 05 05 23 METAL FASTENINGS
05 31 00 STEEL DECKING
05 31 13 STEEL FLOOR
DECKING
05 31 23 STEEL ROOF DECKING

1.0 RECOGNITION

Vulcraft Group and Verco Decking Inc. Steel Deck Panels described in IAPMO UES ER-0423 and this supplement have been evaluated for use as components of floor and roof systems. The structural properties of the steel deck panels were evaluated for compliance with the following codes and regulations:

- 2016 California Building Code (CBC)

2.0 LIMITATIONS

Use of the Vulcraft and Verco Steel Deck Panels recognized in this report is subject to the following limitations:

- 2.1** Diaphragm deflections shall not exceed the permitted relative deflection of walls between the diaphragm level and the floor below. The flexibility limitations shown in Table 1604A.4 of the 2016 California Building Code may be used as a guide in lieu of a rational analysis of the anticipated deflections.
- 2.2** As applicable, in accordance with CBC Section 2210A.1.1.2, the minimum base steel thickness of the steel deck shall be 0.0359 inches (0.9 mm), except for single-story open structures, where the steel deck is not used as a diaphragm and there are no suspended hangers or bracing for nonstructural components attached to the deck.
- 2.3** Special Inspections are required in accordance with CBC Sections 1705.2 and 1705A.2, Steel Construction; and CBC Sections 1705.3 and 1705A.3, Concrete Construction.
- 2.4** Structural Observation is required in accordance with CBC Sections 1704.6 and 1704A.6.
- 2.5** Concrete tests and materials shall comply with CBC Sections 1909.2, 1903A, and 1910A, as applicable.

For additional information about this evaluation report, please visit www.uniform-es.org or email at info@uniform-es.org



LOS ANGELES SUPPLEMENT

NUCOR CORPORATION - VULCRAFT/VERCO GROUP

VULCRAFT GROUP

7205 Gault Avenue North
Fort Payne, Alabama 35967
(256) 845-2460
www.vulcraft.com

VERCO DECKING, INC. a NUCOR Company

4340 North 42nd Avenue
Phoenix, Arizona 85019
(602) 272-1347
www.vercodeck.com

STEEL DECK PANELS

CSI Section: 05 05 23 METAL FASTENINGS
05 31 00 STEEL DECKING
05 31 13 STEEL FLOOR
DECKING
05 31 23 STEEL ROOF DECKING

1.0 RECOGNITION

Vulcraft Group and Verco Decking Inc. Steel Deck Panels described in IAPMO UES ER-0423 and this supplement have been evaluated for use as components of floor and roof systems. The structural properties of the steel deck panels were evaluated for compliance with the following codes and regulations:

- 2017 City of Los Angeles Building Code (LABC)
- 2017 City of Los Angeles Residential Code (LARC)

2.0 LIMITATIONS

Use of the Vulcraft and Verco Steel Deck Panels recognized in ER-0423 and this supplement is subject to the following limitations:

- 2.1 Special Inspections are required in accordance with LABC Section 1705.2, Steel Construction and 1705.3, Concrete Construction.
- 2.2 Structural Observation is required in accordance with LABC Section 1704.6.
- 2.3 Computations and details demonstrating that the loads applied to the decks comply with this report shall be submitted to the Department of Building

and Safety for approval. In accordance with LABC Section 106.3.3.2, computations and drawings shall be prepared and stamped by an engineer or architect licensed by the State of California for the type of service performed except as otherwise permitted by the Department of Building and Safety. In accordance with LABC Section 106.3.3.3, for buildings exceeding 160 feet (49 m) computations and drawings shall be prepared and stamped by a structural engineer licensed by the State of California.

- 2.4 For each job where the deck units are specified, the following information shall be indicated on the plans submitted to the Department of Building and Safety for approval: (a) Cross-section details of the deck panels; (b) fastener details, including deck welding or other fasteners at supports, at diaphragm boundaries parallel to flutes, at shear transfer elements, and at side seams if such fasteners are required; (c) minimum length of deck panels; and (d) design shears.
- 2.5 Deck welding shall be performed by Los Angeles City certified cold-formed steel welders. Prior to proceeding with the welding, the welders shall demonstrate to the Deputy Inspectors their ability to produce the prescribed weld satisfactorily. A sample of the deck material shall be welded to steel simulating the framing. The sample specimen shall then be twisted, and if the deck material tears or if the weld in torsion indicates the proper fusion area, the weld shall be considered satisfactory.
- 2.6 Admixtures containing calcium chloride or other corrosive materials shall not be used in the concrete mix for the slab.
- 2.7 Prior to placement of the concrete for the slab, the steel deck panels shall be cleaned and oil, grease and other materials which may adversely affect the bonding of the concrete to the deck shall be removed.
- 2.8 In structures with long term live loads (i.e., warehouses, computer rooms, file rooms, etc.), the allowable loads in the tables of ER-0423 shall be reduced to account for creep in the concrete.

For additional information about this evaluation report, please visit www.uniform-es.org or email at info@uniform-es.org



TABLE OF CONTENTS

Subject	Page
Diaphragm Shear Strength	7
Proprietary Fasteners	8-9
Proprietary Support Fastener Properties	10
Connections through Perforated Material	10
ITW Buildex SAMMYS X-Press Swivel Head® Connection	11
Wedge-Nut Hanging Load	12
Nominal Strength of #12 Screw thru Perforated Material	13
Nominal Pull-over Strength of #12 Screw thru Solid Material with Slotted Hole	13
Definitions of Section Property Symbols	14
Section Properties	15-18
2.0D, 2.0D FormLok	15
2.0DA	16
3.5D, 3.5D FormLok	17
3.5DA	18



DIAPHRAGM SHEAR STRENGTH AND STIFFNESS

Diaphragm shear strength and stiffness shall be calculated per AISI S310-16 with the following modifications:

D1 Diaphragm Shear Strength per Unit Length Controlled by Connection Strength, S_{nf}

The nominal shear strength [resistance] per unit length of a diaphragm controlled by connection strength, S_{nf} , shall be the smallest of S_{nc} , S_{ne} , and S_{np} .

$$S_{np} = \text{minimum} \left(n_d P_{nf} \frac{12}{w_t} \right) \quad [\text{Eq. D1-4}]$$

Where

S_{np} = Nominal shear strength [resistance] per unit length of diaphragm controlled by connections along the edge perpendicular to the panel span and located at exterior support, kip/ft

n_d = Number of support connections at any given bottom flute along a panel end perpendicular to the panel span and located at exterior support

w_t = Greatest tributary width to any given bottom flute with support connections along the edge perpendicular to the panel span and located at exterior support, in.

All other variables are as defined in AISI S310-16 Section D1

D2.1 Fluted Panel

The nominal diaphragm shear strength [resistance] per unit length, S_{nb} , for either acoustic or non-acoustic fluted panels shall be the smallest of S_{no} and S_{nl} .

$$S_{no} = \alpha \frac{7890}{L_v^2} \left(\frac{I_{xg}^3 t^3 d}{s} \right)^{0.25} \quad [\text{Eq. D2.1-1}]$$

$$S_{nl} = P_n \frac{d - e}{D_d} \left(\frac{12}{d} \right) \quad [\text{Eq. D2.1-2}]$$

Where

α = 1.00 for panels fastened to support at every bottom flute at exterior supports
0.75 for panels not fastened to support at every bottom flute at exterior supports

S_{no} = Nominal diaphragm shear strength [resistance] per unit length controlled by panel out-of-plane buckling, kip/ft

S_{nl} = Nominal diaphragm shear strength [resistance] per unit length controlled by exterior support local web buckling, kip/ft

d = Panel corrugation pitch, in.

e = One-half the bottom flat width of panel measured between points of intercept, in.

D_d = Depth of panel, in.

$$P_n = 4.36t^2 F_y \cdot \sin\theta \cdot \left(1 - 0.04 \sqrt{\frac{R}{t}} \right) \left(1 + 0.25 \sqrt{\frac{N_e}{t}} \right) \left(1 - 0.025 \sqrt{\frac{h_w}{t}} \right) \quad [\text{Eq. D2.1-3}]$$

Where

t = Base steel thickness of panel, in.

F_y = Design yield stress, ksi

θ = Angle between plane of web and plane of bearing surface, deg.

R = Inside bend radius, in.

N_e = Bearing Length at end of panel support, in.

h_w = Flat dimension of web measured in plane of web, in.

D5.1.1 Stiffness of Fluted Panels

For spacing of fasteners connecting panels along longitudinal edges parallel to the deck flutes greater than the interior side-lap seam fastener spacing:

$$d_e \leq \frac{S_s}{S_f} d_s \quad [\text{Eq. G}]$$

Where:

d_e = Spacing of parallel edge fasteners

d_s = Spacing of sidelap fasteners

S_s = Sidelap connection flexibility (in/kip)

S_f = Structural support connection flexibility (in/k)



PROPRIETARY FASTENERS

Hilti

The nominal shear strength [resistance] for the Hilti X-ENP-19 L15 PAF shall be determined in accordance with Eq. H-1:

$$P_{nf} = 56 \cdot t \cdot (1 - t) \leq P_{nvp} \quad [\text{Eq. H-1}]$$

The nominal shear strength [resistance] for the Hilti X-HSN24 PAF shall be determined in accordance with Eq. H-2:

$$P_{nf} = 52 \cdot t \cdot (1 - t) \leq P_{nvp} \quad [\text{Eq. H-2}]$$

The flexibility of the Hilti X-ENP-19 L15 and X-HSN24 PAF shall be determined in accordance with Eq. H-3:

$$S_f = \frac{1.25}{1000\sqrt{t}} \quad [\text{Eq. H-3}]$$

The nominal tension strength [resistance] for the Hilti X-HSN 24 controlled by pull-out shall be determined in accordance with Eq. H-4:

$$P_{not} = 8 \cdot t_{\text{support}} + 0.088 \leq 1.875 \quad \Omega = 2.50 \text{ (ASD)} \quad \phi = 0.65 \text{ (LRFD)} \quad \phi = 0.55 \text{ (LSD)} \quad [\text{Eq. H-4}]$$

The nominal tension strength [resistance] for the X-ENP-19 L15 controlled by pull-out shall be determined in accordance with Eq. H-5:

$$P_{not} = 2.625 \quad \Omega = 2.50 \text{ (ASD)} \quad \phi = 0.65 \text{ (LRFD)} \quad \phi = 0.55 \text{ (LSD)} \quad [\text{Eq. H-5}]$$

Simpson Strong-Tie

The nominal shear strength [resistance] for the Simpson XL Screw shall be determined in accordance with Eq. S-1:

$$P_{nf} = 78 \cdot t \cdot (t_{\text{support}})^{0.15} \leq P_{nvs} \quad [\text{Eq. S-1}]$$

The nominal shear strength [resistance] for the Simpson XM Screw shall be determined in accordance with Eq. S-2a or S-2b:

$$\text{For } t_{\text{support}} \leq 0.1875 \text{ in} \quad P_{nf} = 240 \cdot (t)^{1.5} \leq P_{nvs} \quad [\text{Eq. S-2a}]$$

$$\text{For } t_{\text{support}} > 0.1875 \text{ in} \quad P_{nf} = 53 \cdot t \leq P_{nvs} \quad [\text{Eq. S-2b}]$$

The nominal shear strength [resistance] for the Simpson X1S1016 or XQ1S1016 shall be determined in accordance with Eq. S-3:

$$P_{ns} = 20 \cdot t \leq 1.625 \quad [\text{Eq. S-3}]$$

The nominal shear strength [resistance] for the Simpson XU34B1016 shall be determined in accordance with Eq. S-4:

$$P_{ns} = 25.2 \cdot t \leq 1.735 \quad [\text{Eq. S-4}]$$

Where:

t = Base steel thickness of panel (in.)

t_{support} = Thickness of support (in.)

S_s = Sidelap connection flexibility (in/kip)

S_f = Structural support connection flexibility (in/k)

P_{nf} = Nominal shear strength [resistance] of a support connection (kips)

P_{ns} = Nominal shear strength [resistance] of a side-lap connection per fastener (kips)

P_{nvs} = Nominal shear strength [resistance] of screw (see page 11)

P_{nvp} = Nominal shear strength [resistance] of PAF (see page 11)

P_{not} = Nominal tensile strength [resistance] of a support connection per fastener controlled by pull-out (kips)

φ = Resistance Factor

Ω = Safety Factor



PROPRIETARY FASTENERS (Continued)

Pneutek

The nominal shear strength [resistance] for the Pneutek SDK61 PAF shall be determined in accordance with Eq. P-1a and P-1b:

For substrate thickness equal to 0.113"

$$P_{nf} = 0.735 \cdot t \cdot F_u(1 - 0.016 \cdot t \cdot F_u) \leq P_{nvp} \quad [\text{Eq. P-1a}]$$

For substrate thickness equal to 0.155"

$$P_{nf} = 0.788 \cdot t \cdot F_u(1 - 0.028 \cdot t \cdot F_u) \leq P_{nvp} \quad [\text{Eq. P-1b}]$$

For substrate thickness between 0.113" and 0.155", P_{nf} shall be determined by interpolation.

The nominal shear strength [resistance] for the Pneutek SDK63, K64 and K66 PAF shall be determined in accordance with Eq. P-2:

$$P_{nf} = 1.264 \cdot t \cdot F_u(1 - 0.053 \cdot t \cdot F_u) \leq P_{nvp} \quad [\text{Eq. P-2}]$$

The flexibility of the Pneutek SDK61 PAF shall be determined in accordance with Eq. P-3:

$$S_f = \frac{3}{1000\sqrt{t}} \quad [\text{Eq. P-3}]$$

The flexibility of the Pneutek SDK63, K64 and K66 PAF shall be determined in accordance with Eq. P-4a and P-4b:

For substrate thickness less than 0.25"

$$S_f = \frac{3}{1000\sqrt{t}} \quad [\text{Eq. P-4a}]$$

For substrate thickness equal to or greater than 0.25"

$$S_f = \frac{1}{1000\sqrt{t}} \quad [\text{Eq. P-4b}]$$

The nominal tension strength [resistance] for the Pneutek SDK61, SDK63, K64 and K66 PAF controlled by pull-out shall be determined in accordance with Eq. P-5:

$$P_{not} = 18.37 \cdot t_{support} \leq 4.811 \quad \Omega = 2.45 \text{ (ASD)} \quad \phi = 0.65 \text{ (LRFD)} \quad \phi = 0.55 \text{ (LSD)} \quad [\text{Eq. P-5}]$$

Where:

P_{not} = Nominal tensile strength [resistance] of a support connection per fastener controlled by pull-out (kips)

P_{nf} = Nominal shear strength [resistance] of a support connection per fastener (kips)

t = Base steel thickness of panel (in.)

F_u = Ultimate strength of sheet steel (ksi)

P_{nvp} = Nominal shear strength [resistance] of PAF (see page 11)

$t_{support}$ = Thickness of support (in.)

S_f = Structural support connection flexibility (in/k)

ϕ = Resistance Factor

Ω = Safety Factor



PROPRIETARY SUPPORT FASTENER PROPERTIES ^{1,2}								
Specified Properties	Hilti		Pneutek				Simpson Strong-Tie	
	X-HSN 24	X-ENP-19	SDK61	SDK63	K64	K66	XM Screw	XL Screw
Minimum Substrate Thickness (in)	0.125	0.250	0.113	0.155	0.187	0.281	0.125	0.125
Maximum Substrate Thickness (in)	0.375	∞	0.155	0.250	0.312	∞	0.610	0.610
Minimum Spacing ^{1,2}	1"	1"	1"	1"	1"	1"	11/16"	11/16"
Minimum Edge Distance ^{1,2}	1/2"	1/2"	1/2"	1/2"	1/2"	1/2"	3/8"	3/8"
Shank Diameter (in)	0.157	0.177	0.144	0.173	0.181	0.199	0.216	0.216
Head or Washer Diameter (in)	0.474	0.591	0.500	0.500	0.500	0.500	0.483	0.625
Tensile Strength based on Material strength (kip)	5.033	6.397	3.909	5.641	6.175	7.465	4.985	4.985
Nominal Shear Strength of Screw, P _{nvs} (kip)	-	-	-	-	-	-	3.110	3.110
Nominal Shear Strength of PAF, P _{nvp} (kip)	3.020	3.838	2.345	3.385	3.705	4.479	-	-

¹ Minimum spacing and edge distance for Screws are determined in accordance with AISI S100-16 Section J4.1 and J4.2 respectively.

² Minimum spacing and edge distance for PAF's are determined in accordance with AISI S100-16 Table J5.1-1

CONNECTIONS THROUGH PERFORATED MATERIAL ¹						
Fastener Property	Fastener	Adjustment Factor, ρ	Individual Connections		Diaphragms	
			Ω (ASD)	φ (LRFD)	Ω (ASD)	φ (LRFD)
Nominal Shear Strength	Screw	1.00	3.00	0.50	Per AISI S310 Table B1.1	
	PAF ²	$2.76t + 0.58 \leq 1.00$	2.75	0.60		
	Weld ³	$0.99d + 0.05 \leq 1.00$	2.80	0.55		
Nominal Pullover Strength	Screw, PAF	0.85	3.00	0.50		
Nominal Tension Strength	Weld ^{2,4}	$0.19tF_u + 0.11 \leq 1.00$	3.00	0.50		
Flexibility	Screw	1.71	-			
	PAF	1.15				
	Weld	1.00				

¹ For connections through perforated material, multiply calculated fastener property by appropriate adjustment factor.

² t = Base steel thickness of panel (in.)

³ d = Visible diameter of arc spot weld (in.)

⁴ F_u = Ultimate strength of sheet steel (ksi)

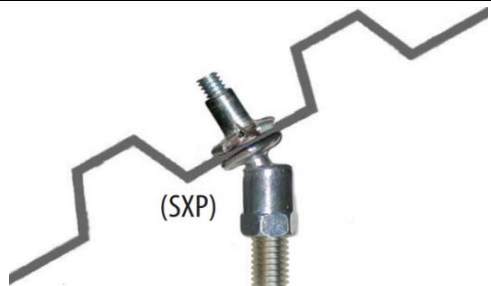

ITW BUILDEX SAMMYS X-PRESS SWIVEL HEAD [®] CONNECTION ¹⁻⁹					
Part Number	Model Number (Threaded Rod Size)	Deck Gage	Connection Strength (lbs)		Part Image
			ASD P_{not}/Ω	LRFD ϕP_{not}	
8294922 8272957	SXP 20 (3/8") SXP 2.0 (1/2)	22	200	320	
		20	240	390	
		19	280	460	
		18	320	520	
8295922 8271957	SXP 35 (3/8") SXP 3.5 (1/2")	16	400	660	
		14	500	820	

¹ P_{not} = Nominal pullout strength of SAMMYS X-Press Swivel Head[®] Connector

² Sammy X-press may be installed in any flat portion of the bottom flange of 2.0D, 2.0DA, 3.5D or 3.5DA as shown in figure below.

³ The load may be applied at any angle, θ , from 0 to 90 degrees, $0 \leq \theta \leq 90$, relative to the axis of the base of the Sammy X-press as shown below.

⁴ The load may be applied at any angle, α , from 0 to 360 degrees, $0 \leq \alpha \leq 360$, relative to the ribs of the steel deck as shown below.

⁵ The allowable strength, P_n/Ω , shall be equal to or greater than the governing load combination for Allowable Stress Design (ASD) as stipulated in the IBC or ASCE/SEI 7.

⁶ The factored strength, ϕP_n , shall be equal to or greater than the governing load combination for Load and Resistance Factor Design as stipulated in the IBC or ASCE/SEI 7.

⁷ Safety and resistance factors included in the table are ASD: $\Omega = 2.5$ and LRFD $\phi = 0.65$ respectively.

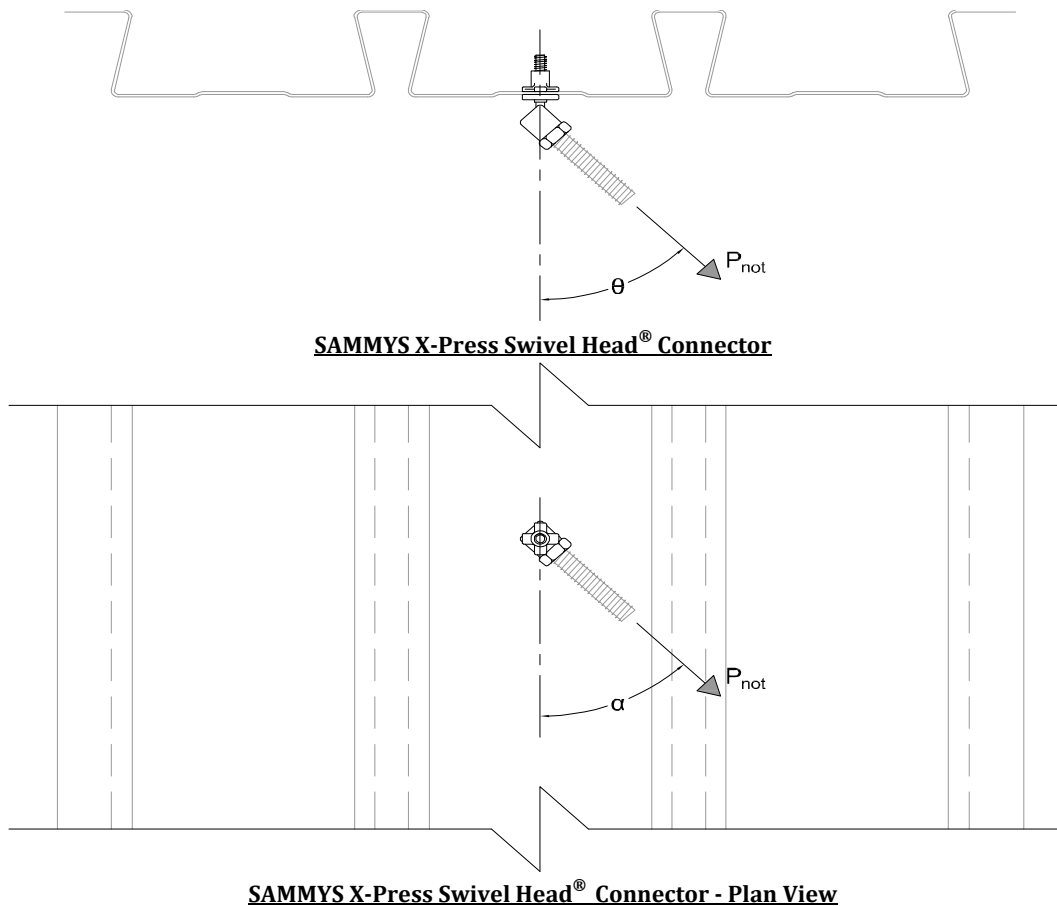



WEDGE-NUT HANGING LOAD ¹⁻⁸				
Deck Type	Part Number	Connection Strength (lbs)		
		Nominal P_n	ASD P_n/Ω	LRFD ϕP_n
2.0D FormLok	2.0D-WN-3/8NC	3828	1392	2297
	2.0D-WN-1/2NC			
3.5D FormLok	3.5D-WN-3/8NC	5490	1996	3294
	3.5D-WN-1/2NC			

¹ Minimum compressive strength of normal (145 pcf) or light weight (≥ 110 pcf) concrete, $f'_c = 2500$ psi.

² The concentrated hanging load shall not exceed the bending strength and vertical shear strength of the 2.0D or 3.5D FormLok Composite Steel Deck-Slab.

³ Hanging load shall not exceed the strength of the threaded rod or bolt provided by others.

⁴ The hanging load shall be applied not more than 5 degrees from normal to the plane of deck.

⁵ The allowable strength, P_n/Ω , shall be equal to or greater than the governing load combination for Allowable Stress Design in the IBC or ASCE/SEI 7.

⁶ The factored strength, ϕP_n , shall be equal to or greater than the governing load combination for Load and Resistance Factor Design in the IBC or ASCE/SEI 7.

⁷ Safety and resistance factors are $\Omega = 2.75$ (ASD) and $\phi = 0.60$ (LRFD) respectively.

⁸ Wedge-nuts shall be installed per manufacturer's instructions.

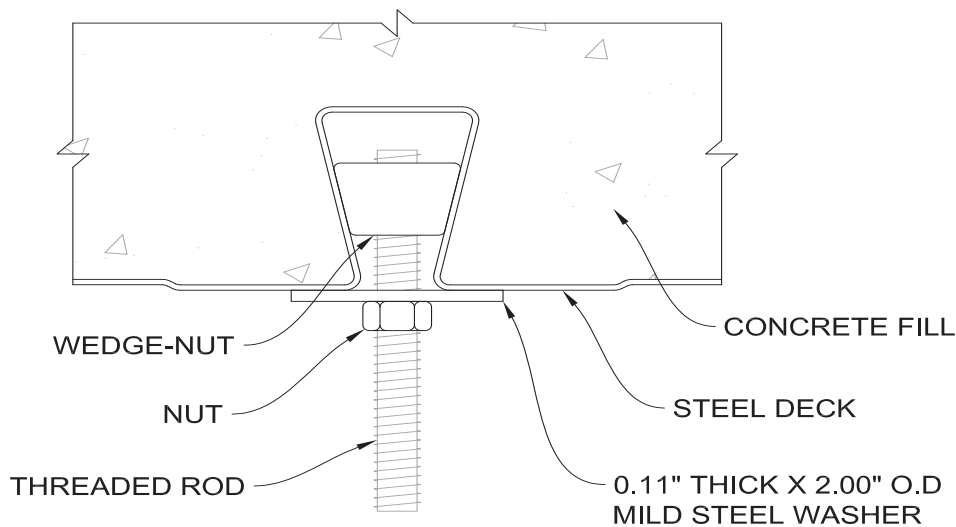

Wedge-nut



NOMINAL STRENGTH OF #12 SCREW INTO PERFORATED MATERIAL (lbs) ¹⁻³		
Deck Type	Shear Strength, P _{ns}	Pull-out Strength, P _{not}
2.0DA22	594	247
2.0DA20	715	322
2.0DA19	829	392
2.0DA18	934	458
2.0DA16	1170	604
3.5DA20	715	322
3.5DA19	829	392
3.5DA18	934	458
3.5DA16	1170	604
3.5DA14	1458	780

¹ Screw must be installed directly into perforation hole.

² Tabulated values are based on perforated material not in contact with the head of the screw. The connecting material in contact with the head of the screw must have a minimum thickness of 16 gage (0.0598") and maximum hole size measuring 1/4" x 5/8".

³ Safety and resistance factors are Ω = 2.50 (ASD) and φ = 0.65 (LRFD) respectively.

NOMINAL PULL-OVER STRENGTH OF #12 SCREW THRU SOLID MATERIAL WITH SLOTTED HOLE ¹⁻⁵		
Gage	t in.	P _{nov} lbs
16	0.0598	971

¹ Maximum slotted hole size = 1/4" x 5/8"

² Tabulated values are based on a minimum effective pull-over resistance diameter, d'_w of 0.423".

³ Tabulated values are based on a minimum tensile strength of steel, F_u of 65 ksi for solid material with slotted hole.

⁴ For eccentrically loaded connections that produce a non-uniform pull-over force on the screw, the nominal pull-over strength shall be taken as 50 percent of P_{nov}

⁵ Safety and resistance factors are Ω = 2.50 (ASD) and φ = 0.65 (LRFD) respectively.

COMBINED SHEAR AND TENSION EQUATIONS		
The following design equations can be used to check shear and tension interaction for assemblies meeting the requirements of the tables shown above:		
ASD:	$\frac{Q}{P_{ns}} + \frac{T}{\min(P_{not}, P_{nov})} \leq \frac{1.0}{\Omega}$	Ω = 2.50
LRFD:	$\frac{\bar{Q}}{P_{ns}} + \frac{\bar{T}}{\min(P_{not}, P_{nov})} \leq 1.0\phi$	φ = 0.65
Where: Q = Required allowable shear strength per connection screw T = Required allowable tension strength per connection screw \bar{Q} = Required shear strength per connection screw \bar{T} = Required tension strength per connection screw		

**DEFINITION OF SECTION PROPERTY SYMBOLS**

Symbol	Definition	Units
A_g	Gross area of cross-section	in ² /ft
A_n	Net area of cross-section	in ² /ft
c_p	Perforation hole center-to-center spacing	in.
d_p	Perforation hole diameter	in.
E_p	Width of perforated band in bottom flange	in.
h_w	Flat dimension of web measured in plane of web	in.
I_{d+}	Positive effective moment of inertia for deflection due to uniform loads, $I_{d+}=(2I_{e+}+I_x)/3$	in ⁴ /ft
I_{d-}	Negative effective moment of inertia for deflection due to uniform loads, $I_{d-}=(2I_{e-}+I_x)/3$	in ⁴ /ft
I_{e+}	Positive effective moment of inertia	in ⁴ /ft
I_{e-}	Negative effective moment of inertia	in ⁴ /ft
I_{xg}	Moment of inertia of fully effective section	in ⁴ /ft
K	Composite deck coefficient	-
M_{n+}	Nominal positive flexural strength of deck or panel	k-ft/ft
M_{n-}	Nominal negative flexural strength of deck or panel	k-ft/ft
M_{nxt+}	Nominal positive flexural strength with respect to centroidal axis in considering tension yielding	k-ft/ft
M_{nxt-}	Nominal negative flexural strength with respect to centroidal axis in considering tension yielding	k-ft/ft
R	Inside bend radius	in.
r	Radius of gyration of full unreduced section	in.
S_{e+}	Positive effective section modulus	in ³ /ft
S_{e-}	Negative effective section modulus	in ³ /ft
S_{ft+}	Positive section modulus of full unreduced section	in ³ /ft
S_{ft-}	Negative section modulus of full unreduced section	in ³ /ft
T_n	Nominal tensile axial strength of panel	k/ft
t	Base steel thickness of panel	in.
V_n	Nominal vertical shear strength of panel	k/ft
w_{bf}	Flat width of bottom flange	in.
w_{dd}	Weight of section	psf
w_{tf}	Flat width of top flange	in.
y_b	Distance from extreme bottom fiber to neutral axis of gross section	in.
y_t	Distance from extreme top fiber to neutral axis of gross section	in.
θ	Angle between plane of web and plane of bearing surface	deg.



Non-Composite Profiles

2.0D

Composite Profiles

2.0D FormLok

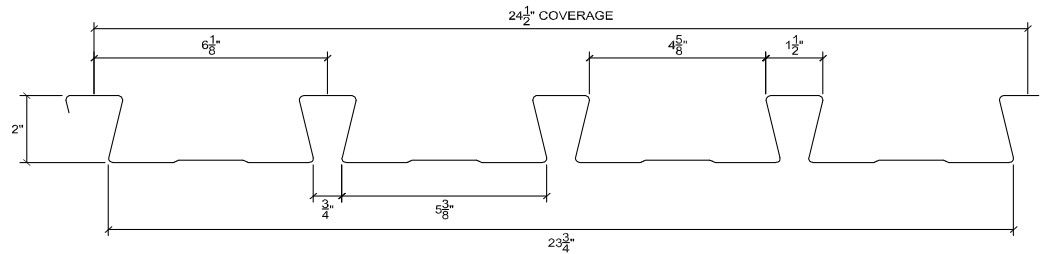

Gage	t in.	w _{dd} psf	A _g in ² /ft	I _{xg} in ⁴ /ft	S _{ft+} in ³ /ft	S _{ft-} in ³ /ft	y _b in.	y _t in.	r in.	h _w in.	θ deg.
22	0.0295	2.1	0.626	0.388	0.560	0.290	0.693	1.337	0.787	1.698	79.6
20	0.0358	2.6	0.761	0.472	0.677	0.353	0.697	1.339	0.788	1.691	79.4
19	0.0418	3.0	0.889	0.551	0.787	0.411	0.700	1.342	0.787	1.683	79.2
18	0.0474	3.4	1.009	0.626	0.889	0.466	0.704	1.343	0.788	1.677	78.9
16	0.0598	4.3	1.276	0.792	1.114	0.587	0.711	1.349	0.788	1.662	78.4

GRADE 40: F _y = 40 ksi, F _u = 55 ksi												
Gage	I _{e+} in ⁴ /ft	I _{e-} in ⁴ /ft	I _{d+} in ⁴ /ft	I _{d-} in ⁴ /ft	S _{e+} in ³ /ft	S _{e-} in ³ /ft	M _{n+} k-ft/ft	M _{n-} k-ft/ft	M _{nxt+} k-ft/ft	M _{nxt-} k-ft/ft	V _n k/ft	T _n k/ft
22	0.386	0.345	0.387	0.359	0.272	0.272	0.907	0.907	1.867	0.967	4.633	25.04
20	0.472	0.435	0.472	0.447	0.343	0.334	1.143	1.113	2.257	1.177	5.596	30.44
19	0.551	0.523	0.551	0.532	0.406	0.394	1.353	1.313	2.623	1.370	6.499	35.56
18	0.626	0.605	0.626	0.612	0.463	0.450	1.543	1.500	2.963	1.553	7.335	40.36
16	0.792	0.791	0.792	0.791	0.587	0.576	1.957	1.920	3.713	1.957	9.156	51.04

R	w _{tf}	w _{bf}
in.	in.	in.
0.125	1.188	5.000

K
-
0.76



Acoustic Profiles

2.0DA

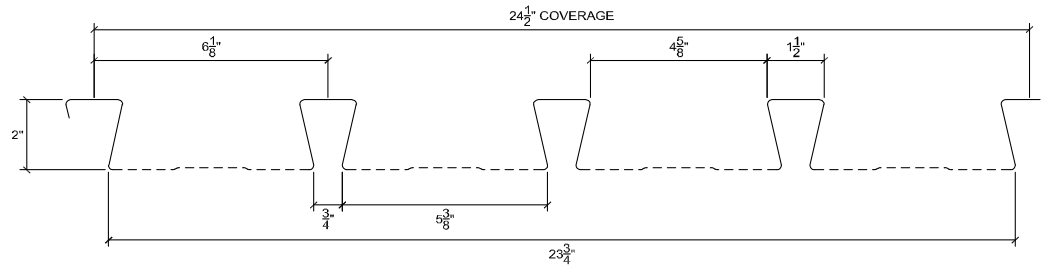

Gage	t in.	w _{dd} psf	A _g in ² /ft	A _n in ² /ft	I _{xg} in ⁴ /ft	S _{ft+} in ³ /ft	S _{ft-} in ³ /ft	y _b in.	y _t in.	r in.	h _w in.	θ deg.
22	0.0295	2.0	0.626	0.583	0.341	0.422	0.279	0.808	1.222	0.738	1.698	79.6
20	0.0358	2.4	0.761	0.708	0.415	0.512	0.339	0.811	1.225	0.738	1.691	79.4
19	0.0418	2.8	0.889	0.828	0.485	0.595	0.395	0.815	1.227	0.739	1.683	79.2
18	0.0474	3.2	1.009	0.940	0.551	0.674	0.448	0.818	1.229	0.739	1.677	78.9
16	0.0598	4.0	1.276	1.188	0.697	0.845	0.564	0.825	1.235	0.739	1.662	78.4

GRADE 40: F _y = 40 ksi, F _u = 55 ksi												
Gage	I _{e+} in ⁴ /ft	I _{e-} in ⁴ /ft	I _{d+} in ⁴ /ft	I _{d-} in ⁴ /ft	S _{e+} in ³ /ft	S _{e-} in ³ /ft	M _{n+} k-ft/ft	M _{n-} k-ft/ft	M _{nxt+} k-ft/ft	M _{nxt-} k-ft/ft	V _n k/ft	T _n k/ft
22	0.339	0.294	0.340	0.310	0.261	0.258	0.870	0.860	1.407	0.930	4.633	23.32
20	0.415	0.370	0.415	0.385	0.330	0.317	1.100	1.057	1.707	1.130	5.596	28.32
19	0.485	0.445	0.485	0.458	0.391	0.374	1.303	1.247	1.983	1.317	6.499	33.12
18	0.551	0.516	0.551	0.528	0.445	0.427	1.483	1.423	2.247	1.493	7.335	37.60
16	0.697	0.677	0.697	0.684	0.564	0.546	1.880	1.820	2.817	1.880	9.156	47.52

R	w _{tf}	w _{br}
in.	in.	in.
0.125	1.188	5.000

d _p	c _p	E _p
in.	in.	in.
0.154	0.375	4.654



Non-Composite Profiles

3.5D

Composite Profiles

3.5D FormLok

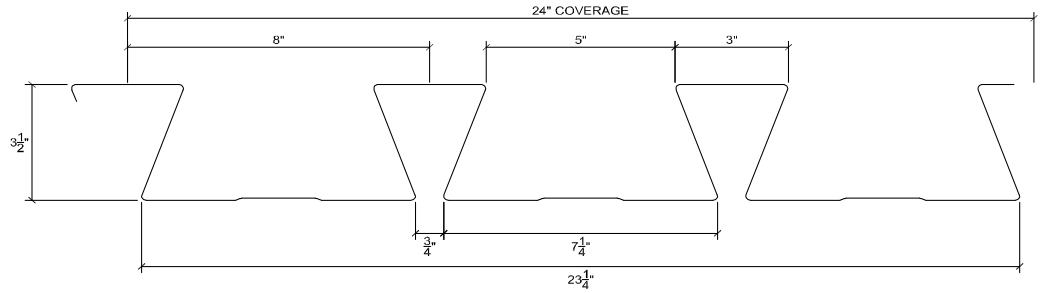

Gage	t in.	w _{dd} psf	A _g in ² /ft	I _{xg} in ⁴ /ft	S _{ft+} in ³ /ft	S _{ft-} in ³ /ft	y _b in.	y _t in.	r in.	h _w in.	θ deg.
20	0.0358	3.3	0.955	1.891	1.361	0.881	1.389	2.147	1.407	3.293	71.6
19	0.0418	3.8	1.116	2.210	1.588	1.028	1.392	2.150	1.407	3.286	71.4
18	0.0474	4.3	1.266	2.508	1.798	1.165	1.395	2.152	1.407	3.280	71.3
16	0.0598	5.4	1.600	3.170	2.261	1.469	1.402	2.158	1.408	3.267	71.0

GRADE 40: F _y = 40 ksi, F _u = 55 ksi												
Gage	I _{e+} in ⁴ /ft	I _{e-} in ⁴ /ft	I _{d+} in ⁴ /ft	I _{d-} in ⁴ /ft	S _{e+} in ³ /ft	S _{e-} in ³ /ft	M _{n+} k-ft/ft	M _{n-} k-ft/ft	M _{nxt+} k-ft/ft	M _{nxt-} k-ft/ft	V _n k/ft	T _n k/ft
20	1.697	1.524	1.762	1.646	0.676	0.781	2.253	2.603	4.537	2.937	5.496	38.20
19	2.039	1.845	2.096	1.967	0.837	0.934	2.790	3.113	5.293	3.427	7.484	44.64
18	2.368	2.154	2.415	2.272	0.980	1.070	3.267	3.567	5.993	3.883	9.619	50.64
16	3.115	2.867	3.133	2.968	1.317	1.377	4.390	4.590	7.537	4.897	13.300	64.00

R	w _{tr}	w _{br}
in.	in.	in.
0.125	2.688	6.850

K
-
1.12



Acoustic Profiles

3.5DA

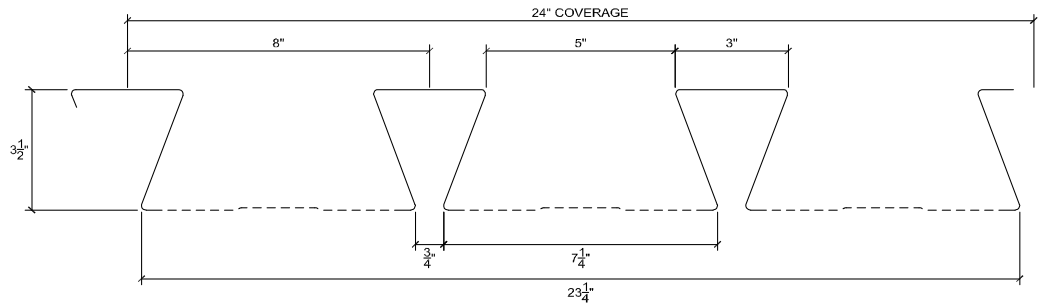

Gage	t in.	w _{dd} psf	A _g in ² /ft	A _n in ² /ft	I _{xg} in ⁴ /ft	S _{ft+} in ³ /ft	S _{ft-} in ³ /ft	y _b in.	y _t in.	r in.	h _w in.	θ deg.
20	0.0358	3.1	0.955	0.899	1.639	1.035	0.840	1.584	1.952	1.310	3.293	71.6
19	0.0418	3.6	1.116	1.050	1.915	1.206	0.980	1.588	1.954	1.310	3.286	71.4
18	0.0474	4.1	1.266	1.192	2.174	1.366	1.111	1.591	1.956	1.310	3.280	71.3
16	0.0598	5.1	1.600	1.506	2.748	1.720	1.401	1.598	1.962	1.311	3.267	71.0

GRADE 40: F _y = 40 ksi, F _u = 55 ksi												
Gage	I _{e+} in ⁴ /ft	I _{e-} in ⁴ /ft	I _{d+} in ⁴ /ft	I _{d-} in ⁴ /ft	S _{e+} in ³ /ft	S _{e-} in ³ /ft	M _{n+} k-ft/ft	M _{n-} k-ft/ft	M _{nxt+} k-ft/ft	M _{nxt-} k-ft/ft	V _n k/ft	T _n k/ft
20	1.477	1.325	1.531	1.430	0.655	0.657	2.183	2.190	3.450	2.800	5.496	35.96
19	1.775	1.587	1.822	1.696	0.797	0.794	2.657	2.647	4.020	3.267	7.484	42.00
18	2.060	1.838	2.098	1.950	0.934	0.928	3.113	3.093	4.553	3.703	9.619	47.68
16	2.704	2.425	2.719	2.533	1.255	1.241	4.183	4.137	5.733	4.670	13.300	60.24

R	w _{tr}	w _{br}
in.	in.	in.
0.125	2.688	6.850

d _p	c _p	E _p
in.	in.	in.
0.156	0.375	6.344